



# Two-Tier GCSE Mathematics Homework

## Pack 2: Higher Tier

Stafford Burdred  
Consultant editor: Duncan Smith



ISBN-10: 1 84070 642 2  
ISBN-13: 978 1 84070 642 0

© Pearson Publishing 1997  
Published by Pearson Publishing 1997  
Revised 2006

A licence to copy the material in this pack is only granted to the purchaser strictly within their school, college or organisation. The material must not be reproduced in any other form without the express written permission of Pearson Publishing.

Pearson Publishing, Chesterton Mill, French's Road, Cambridge CB4 3NP Tel 01223 350555 Fax 01223 356484  
[www.pearsonpublishing.co.uk](http://www.pearsonpublishing.co.uk)

# 1 Rational and irrational numbers

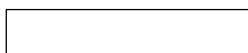

In each question, decide whether the number is rational or irrational. If the number is rational, write the number in the form  $\frac{a}{b}$ . If the number is irrational, write 'irrational'.

1  $\sqrt{9}$  1.....

2  $\sqrt{13}$  2.....

3  $\frac{5\pi}{10\pi}$  3.....

4  $\sqrt{17} \times \sqrt{17}$  4.....

5 0.36 5.....

6  $\sqrt{8} + \sqrt{8}$  6.....

7  $0.\dot{3}\dot{7}$  7.....

8  $5\pi$  8.....

9  $6\pi \times 3\pi$  9.....

10  $3\pi + 3\pi$  10.....

11  $0.0\dot{8}$  11.....

12 0.377 12.....

13  $0.\dot{2}\dot{4}\dot{5}$  13.....

14 0.07 14.....

15  $0.\dot{6}$  15.....

16  $7 < x < 40$   
 $\sqrt{7} \times \sqrt{x}$  is rational.  
 Write down a possible value of x. 16.....

17  $170 < a < 210$   
 $\sqrt{8} \times \sqrt{a}$  is rational.  
 Write down a possible value of x.  17.....

## 2 Checking

Round the following numbers to one significant figure.

- |   |        |                                 |
|---|--------|---------------------------------|
| 1 | 783    | 1..... <input type="checkbox"/> |
| 2 | 479    | 2..... <input type="checkbox"/> |
| 3 | 32.75  | 3..... <input type="checkbox"/> |
| 4 | 41.99  | 4..... <input type="checkbox"/> |
| 5 | 0.0609 | 5..... <input type="checkbox"/> |
| 6 | 3.097  | 6..... <input type="checkbox"/> |
| 7 | 0.317  | 7..... <input type="checkbox"/> |
| 8 | 0.0989 | 8..... <input type="checkbox"/> |

Estimate the answer to these questions (show your working).

- |    |                                                       |                                  |
|----|-------------------------------------------------------|----------------------------------|
| 9  | 3917 x 41.07                                          | 9..... <input type="checkbox"/>  |
| 10 | 5127 x 0.092                                          | 10..... <input type="checkbox"/> |
| 11 | 0.068 x 0.1132                                        | 11..... <input type="checkbox"/> |
| 12 | 9.07 ÷ 29.97                                          | 12..... <input type="checkbox"/> |
| 13 | 16 081 ÷ 0.0398                                       | 13..... <input type="checkbox"/> |
| 14 | 69.8(18.93 – 9.24)                                    | 14..... <input type="checkbox"/> |
| 15 | $\frac{8.13 + 9.07^2 + \sqrt{26}}{\sqrt{401} - 4.98}$ | 15..... <input type="checkbox"/> |

15.....

### 3 Using a calculator: Brackets and memory

Give your answer to six significant figures. Show your calculator keys for questions 1 and 6.

1  $4.6(5.1 - 8.67)$

1.....

2  $2.38(4.2^3 - \sqrt{6.8})$

2.....

3  $(3.7^4 - \sqrt[4]{88.6})5.8$

3.....

4  $(8^4 - \sqrt{3078})(5^3 - \sqrt[3]{608})$

4.....

5  $\frac{7.36 \times 5.4}{17.84 - 3.72}$

5.....

6  $\frac{14.6^2 - 2.8^3}{4.3 - \sqrt{23.2}}$

6.....

7  $\frac{5.3(6.8^3 - 1.7^4)}{6^5 - 8^3}$

7.....

8  $\frac{4.26^3 \times 2.8^4}{7.2 \times \sqrt[4]{7873}}$

8.....

The make and type of my calculator is: .....

## 4 Using a calculator: Powers, roots, memory

Use your calculator to find the answers. Show your calculator keys. Give your answer correct to six significant figures where appropriate.

1  $5.6^2$                  1.....

2  $\sqrt{38.7}$                  2.....

3  $2.5^8$                  3.....

4  $\sqrt[3]{721}$                  4.....

5  $428^{2/5}$                  5.....

6  $\sqrt[6]{888}$                  6.....

7  $12^{-1/4}$                  7.....

8  $8^{-3}$                  8.....

9  $y = 2x^3 + 4x^2 - 3x + 3$

Calculate the value of y when x = 2.874. Use an efficient calculator method.

9.....

10  $y = 4x^3 - 3x^2 + 2x - 4$

Calculate the value of y when x = -5.73. Use an efficient calculator method.

10.....

The make and type of my calculator is: .....

## 5 Standard form – 1

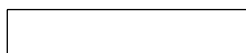

Write the following as ordinary numbers.

- 1  $6.3 \times 10^4$  1.....
- 2  $4.2 \times 10^3$  2.....
- 3  $3.72 \times 10^{-2}$  3.....
- 4  $2.63 \times 10^{-4}$  4.....
- 5  $5.1 \times 10^6$  5.....
- 6  $4.3 \times 10^2$  6.....
- 7  $2.8 \times 10^{-1}$  7.....
- 8  $7.1 \times 10^{-5}$  8.....

Write the following numbers in standard form.

- 9 360 9.....
- 10 2400 10.....
- 11 482000 11.....
- 12 0.37 12.....
- 13 0.00682 13.....
- 14 0.072 14.....
- 15 38000 15.....
- 16 0.00035 16.....



## 6 Standard form – 2

Write the following as ordinary numbers.

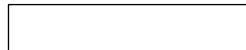

- |   |                         |         |                          |
|---|-------------------------|---------|--------------------------|
| 1 | 4.8 x 10 <sup>5</sup>   | 1 ..... | <input type="checkbox"/> |
| 2 | 6.2 x 10 <sup>2</sup>   | 2 ..... | <input type="checkbox"/> |
| 3 | 4.7 x 10 <sup>-3</sup>  | 3 ..... | <input type="checkbox"/> |
| 4 | 2.74 x 10 <sup>-5</sup> | 4 ..... | <input type="checkbox"/> |
| 5 | 8.1 x 10 <sup>6</sup>   | 5 ..... | <input type="checkbox"/> |
| 6 | 3.4 x 10 <sup>-1</sup>  | 6 ..... | <input type="checkbox"/> |
| 7 | 7.2 x 10 <sup>-4</sup>  | 7 ..... | <input type="checkbox"/> |
| 8 | 1.32 x 10 <sup>-3</sup> | 8 ..... | <input type="checkbox"/> |

Write the following numbers in standard form.

- |    |          |          |                          |
|----|----------|----------|--------------------------|
| 9  | 730      | 9 .....  | <input type="checkbox"/> |
| 10 | 6820     | 10 ..... | <input type="checkbox"/> |
| 11 | 372 000  | 11 ..... | <input type="checkbox"/> |
| 12 | 0.642    | 12 ..... | <input type="checkbox"/> |
| 13 | 0.00078  | 13 ..... | <input type="checkbox"/> |
| 14 | 0.0823   | 14 ..... | <input type="checkbox"/> |
| 15 | 2700     | 15 ..... | <input type="checkbox"/> |
| 16 | 0.000042 | 16 ..... | <input type="checkbox"/> |

Give the answers to the following: a in standard form (correct to three significant figures); b as ordinary numbers (correct to six significant figures where appropriate). Show your calculator keys for question 19.

- |    |                                                 |           |                          |
|----|-------------------------------------------------|-----------|--------------------------|
| 17 | 5.2 x 10 <sup>2</sup> x 3.6 x 10 <sup>3</sup>   | 17a ..... | <input type="checkbox"/> |
|    |                                                 | b .....   | <input type="checkbox"/> |
| 18 | 7.21 x 10 <sup>6</sup> x 4.7 x 10 <sup>-3</sup> | 18a ..... | <input type="checkbox"/> |
|    |                                                 | b .....   | <input type="checkbox"/> |

- |                          |                                                                                                     |                                                                                                                                                                                                                                                                                                                                                                                                                                                                                                                                                                                                                                                                                                                                                                                                                                                                                                                                                                                                                                                                                                                                                                                                                                                                                                                                                                                                                                                                                                                                                                                                                                           |                          |                          |                          |                          |                          |                          |                          |                          |                          |                          |                          |                          |                          |                          |                          |                          |                          |                          |                          |                          |                          |                          |                          |                          |                          |                          |                          |                          |                          |                          |                          |                          |                          |                          |                          |                          |                          |                          |                          |                          |                          |                          |                          |                          |           |                          |
|--------------------------|-----------------------------------------------------------------------------------------------------|-------------------------------------------------------------------------------------------------------------------------------------------------------------------------------------------------------------------------------------------------------------------------------------------------------------------------------------------------------------------------------------------------------------------------------------------------------------------------------------------------------------------------------------------------------------------------------------------------------------------------------------------------------------------------------------------------------------------------------------------------------------------------------------------------------------------------------------------------------------------------------------------------------------------------------------------------------------------------------------------------------------------------------------------------------------------------------------------------------------------------------------------------------------------------------------------------------------------------------------------------------------------------------------------------------------------------------------------------------------------------------------------------------------------------------------------------------------------------------------------------------------------------------------------------------------------------------------------------------------------------------------------|--------------------------|--------------------------|--------------------------|--------------------------|--------------------------|--------------------------|--------------------------|--------------------------|--------------------------|--------------------------|--------------------------|--------------------------|--------------------------|--------------------------|--------------------------|--------------------------|--------------------------|--------------------------|--------------------------|--------------------------|--------------------------|--------------------------|--------------------------|--------------------------|--------------------------|--------------------------|--------------------------|--------------------------|--------------------------|--------------------------|--------------------------|--------------------------|--------------------------|--------------------------|--------------------------|--------------------------|--------------------------|--------------------------|--------------------------|--------------------------|--------------------------|--------------------------|--------------------------|--------------------------|-----------|--------------------------|
| 19                       | $\frac{2.8 \times 10^3 \times 4.2 \times 10^5}{4.7 \times 10^{-3} \times 2.8 \times 10^6}$          | <table style="width: 100%; border-collapse: collapse;"> <tr><td style="width: 20px;"><input type="checkbox"/></td><td><input type="checkbox"/></td><td><input type="checkbox"/></td><td><input type="checkbox"/></td><td><input type="checkbox"/></td><td><input type="checkbox"/></td><td><input type="checkbox"/></td><td><input type="checkbox"/></td><td><input type="checkbox"/></td><td><input type="checkbox"/></td><td><input type="checkbox"/></td></tr> <tr><td><input type="checkbox"/></td><td><input type="checkbox"/></td><td><input type="checkbox"/></td><td><input type="checkbox"/></td><td><input type="checkbox"/></td><td><input type="checkbox"/></td><td><input type="checkbox"/></td><td><input type="checkbox"/></td><td><input type="checkbox"/></td><td><input type="checkbox"/></td><td><input type="checkbox"/></td></tr> <tr><td><input type="checkbox"/></td><td><input type="checkbox"/></td><td><input type="checkbox"/></td><td><input type="checkbox"/></td><td><input type="checkbox"/></td><td><input type="checkbox"/></td><td><input type="checkbox"/></td><td><input type="checkbox"/></td><td><input type="checkbox"/></td><td><input type="checkbox"/></td><td><input type="checkbox"/></td></tr> <tr><td><input type="checkbox"/></td><td><input type="checkbox"/></td><td><input type="checkbox"/></td><td><input type="checkbox"/></td><td><input type="checkbox"/></td><td><input type="checkbox"/></td><td><input type="checkbox"/></td><td><input type="checkbox"/></td><td><input type="checkbox"/></td><td><input type="checkbox"/></td><td><input type="checkbox"/></td></tr> </table> | <input type="checkbox"/> | <input type="checkbox"/> | <input type="checkbox"/> | <input type="checkbox"/> | <input type="checkbox"/> | <input type="checkbox"/> | <input type="checkbox"/> | <input type="checkbox"/> | <input type="checkbox"/> | <input type="checkbox"/> | <input type="checkbox"/> | <input type="checkbox"/> | <input type="checkbox"/> | <input type="checkbox"/> | <input type="checkbox"/> | <input type="checkbox"/> | <input type="checkbox"/> | <input type="checkbox"/> | <input type="checkbox"/> | <input type="checkbox"/> | <input type="checkbox"/> | <input type="checkbox"/> | <input type="checkbox"/> | <input type="checkbox"/> | <input type="checkbox"/> | <input type="checkbox"/> | <input type="checkbox"/> | <input type="checkbox"/> | <input type="checkbox"/> | <input type="checkbox"/> | <input type="checkbox"/> | <input type="checkbox"/> | <input type="checkbox"/> | <input type="checkbox"/> | <input type="checkbox"/> | <input type="checkbox"/> | <input type="checkbox"/> | <input type="checkbox"/> | <input type="checkbox"/> | <input type="checkbox"/> | <input type="checkbox"/> | <input type="checkbox"/> | <input type="checkbox"/> | <input type="checkbox"/> | 19a ..... | <input type="checkbox"/> |
| <input type="checkbox"/> | <input type="checkbox"/>                                                                            | <input type="checkbox"/>                                                                                                                                                                                                                                                                                                                                                                                                                                                                                                                                                                                                                                                                                                                                                                                                                                                                                                                                                                                                                                                                                                                                                                                                                                                                                                                                                                                                                                                                                                                                                                                                                  | <input type="checkbox"/> | <input type="checkbox"/> | <input type="checkbox"/> | <input type="checkbox"/> | <input type="checkbox"/> | <input type="checkbox"/> | <input type="checkbox"/> | <input type="checkbox"/> |                          |                          |                          |                          |                          |                          |                          |                          |                          |                          |                          |                          |                          |                          |                          |                          |                          |                          |                          |                          |                          |                          |                          |                          |                          |                          |                          |                          |                          |                          |                          |                          |                          |                          |                          |                          |           |                          |
| <input type="checkbox"/> | <input type="checkbox"/>                                                                            | <input type="checkbox"/>                                                                                                                                                                                                                                                                                                                                                                                                                                                                                                                                                                                                                                                                                                                                                                                                                                                                                                                                                                                                                                                                                                                                                                                                                                                                                                                                                                                                                                                                                                                                                                                                                  | <input type="checkbox"/> | <input type="checkbox"/> | <input type="checkbox"/> | <input type="checkbox"/> | <input type="checkbox"/> | <input type="checkbox"/> | <input type="checkbox"/> | <input type="checkbox"/> |                          |                          |                          |                          |                          |                          |                          |                          |                          |                          |                          |                          |                          |                          |                          |                          |                          |                          |                          |                          |                          |                          |                          |                          |                          |                          |                          |                          |                          |                          |                          |                          |                          |                          |                          |                          |           |                          |
| <input type="checkbox"/> | <input type="checkbox"/>                                                                            | <input type="checkbox"/>                                                                                                                                                                                                                                                                                                                                                                                                                                                                                                                                                                                                                                                                                                                                                                                                                                                                                                                                                                                                                                                                                                                                                                                                                                                                                                                                                                                                                                                                                                                                                                                                                  | <input type="checkbox"/> | <input type="checkbox"/> | <input type="checkbox"/> | <input type="checkbox"/> | <input type="checkbox"/> | <input type="checkbox"/> | <input type="checkbox"/> | <input type="checkbox"/> |                          |                          |                          |                          |                          |                          |                          |                          |                          |                          |                          |                          |                          |                          |                          |                          |                          |                          |                          |                          |                          |                          |                          |                          |                          |                          |                          |                          |                          |                          |                          |                          |                          |                          |                          |                          |           |                          |
| <input type="checkbox"/> | <input type="checkbox"/>                                                                            | <input type="checkbox"/>                                                                                                                                                                                                                                                                                                                                                                                                                                                                                                                                                                                                                                                                                                                                                                                                                                                                                                                                                                                                                                                                                                                                                                                                                                                                                                                                                                                                                                                                                                                                                                                                                  | <input type="checkbox"/> | <input type="checkbox"/> | <input type="checkbox"/> | <input type="checkbox"/> | <input type="checkbox"/> | <input type="checkbox"/> | <input type="checkbox"/> | <input type="checkbox"/> |                          |                          |                          |                          |                          |                          |                          |                          |                          |                          |                          |                          |                          |                          |                          |                          |                          |                          |                          |                          |                          |                          |                          |                          |                          |                          |                          |                          |                          |                          |                          |                          |                          |                          |                          |                          |           |                          |
|                          |                                                                                                     |                                                                                                                                                                                                                                                                                                                                                                                                                                                                                                                                                                                                                                                                                                                                                                                                                                                                                                                                                                                                                                                                                                                                                                                                                                                                                                                                                                                                                                                                                                                                                                                                                                           | b .....                  | <input type="checkbox"/> |                          |                          |                          |                          |                          |                          |                          |                          |                          |                          |                          |                          |                          |                          |                          |                          |                          |                          |                          |                          |                          |                          |                          |                          |                          |                          |                          |                          |                          |                          |                          |                          |                          |                          |                          |                          |                          |                          |                          |                          |                          |                          |           |                          |
| 20                       | $\frac{4.6 \times 10^{-3} \times 6.2 \times 10^{-3}}{1.8 \times 10^{-1} \times 3.6 \times 10^{-4}}$ | 20a .....                                                                                                                                                                                                                                                                                                                                                                                                                                                                                                                                                                                                                                                                                                                                                                                                                                                                                                                                                                                                                                                                                                                                                                                                                                                                                                                                                                                                                                                                                                                                                                                                                                 | <input type="checkbox"/> |                          |                          |                          |                          |                          |                          |                          |                          |                          |                          |                          |                          |                          |                          |                          |                          |                          |                          |                          |                          |                          |                          |                          |                          |                          |                          |                          |                          |                          |                          |                          |                          |                          |                          |                          |                          |                          |                          |                          |                          |                          |                          |                          |           |                          |
|                          |                                                                                                     | b .....                                                                                                                                                                                                                                                                                                                                                                                                                                                                                                                                                                                                                                                                                                                                                                                                                                                                                                                                                                                                                                                                                                                                                                                                                                                                                                                                                                                                                                                                                                                                                                                                                                   | <input type="checkbox"/> |                          |                          |                          |                          |                          |                          |                          |                          |                          |                          |                          |                          |                          |                          |                          |                          |                          |                          |                          |                          |                          |                          |                          |                          |                          |                          |                          |                          |                          |                          |                          |                          |                          |                          |                          |                          |                          |                          |                          |                          |                          |                          |                          |           |                          |

- |    |                                        |           |                          |
|----|----------------------------------------|-----------|--------------------------|
| 21 | (3.2 x 10 <sup>-1</sup> ) <sup>3</sup> | 21a ..... | <input type="checkbox"/> |
|    |                                        | b .....   | <input type="checkbox"/> |

The make and type of my calculator is: .....



## 7 Percentages and fractions

- |                                                                                            |                                    |
|--------------------------------------------------------------------------------------------|------------------------------------|
| 1 Find 7% of 68.                                                                           | 1..... <input type="checkbox"/>    |
| 2 Find 27% of 42.                                                                          | 2..... <input type="checkbox"/>    |
| 3 Increase 30 by 6%.                                                                       | 3..... <input type="checkbox"/>    |
| 4 Increase 71 by 13%.                                                                      | 4..... <input type="checkbox"/>    |
| 5 Decrease 43 by 27%.                                                                      | 5..... <input type="checkbox"/>    |
| 6 Decrease 6.7 by 17%.                                                                     | 6..... <input type="checkbox"/>    |
| 7 Find $\frac{3}{5}$ of 27.                                                                | 7..... <input type="checkbox"/>    |
| 8 Increase 38 by $\frac{3}{8}$ .                                                           | 8..... <input type="checkbox"/>    |
| 9 Decrease 16 by $\frac{1}{5}$ .                                                           | 9..... <input type="checkbox"/>    |
| 10 Mrs White earns £28 000 pa. She receives a 4.2% rise each year.                         |                                    |
| a How much does she receive after one year?                                                | 10a ..... <input type="checkbox"/> |
| b How much does she receive after eight years?<br>(Give your answer to the nearest pound.) | b ..... <input type="checkbox"/>   |
| 11 A meal cost £44.65 including 17.5% VAT.                                                 |                                    |
| a What was the cost before VAT was added?                                                  | 11a ..... <input type="checkbox"/> |
| b How much was the VAT?                                                                    | b ..... <input type="checkbox"/>   |
| 12 A television cost £520 + 17.5% VAT. What was the total cost?                            | 12..... <input type="checkbox"/>   |



## 8 Calculating growth and decay rates

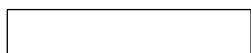

- 1 A car was bought in 2002 for £16 000. Its value depreciated by 15% per year.
- a What was its value in 2003? 1a.....
  - b What was its value in 2004? b.....
  - c What will its value be in 2008? (Give your answer to the nearest pound.) c.....
  - d In which year will its value first fall below £3000? d .....
- 2 A man's salary increases by 4% per year. He earned £24 000 pa in 2000. Give your answers to the nearest pound.
- a How much did he earn in 2003? 2a.....
  - b How much will he earn in 2010? b.....
  - c In which year will his salary reach £48 000? c.....
  - d How much did he earn in 1997? d .....
  - e How much did he earn in 1993? e.....
- 3 A population of bears decreases by 6% per year. In 1994 there were 20 000 bears.
- a How many bears were there in:
    - i 1988 3a i.....
    - ii 2000 ii.....
    - iii 2002? iii .....
  - b When the number of bears falls below 8000 they will be declared an endangered species. In which year will they be declared an endangered species? b.....



# 9 Patterns you must recognise

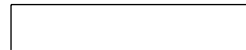

- a Complete the missing numbers in these sequences.
- b Name the sequences.

1 1, 4, \_\_, 16, 25, 36, \_\_, 64

1a .....

b .....

2 1, 1, 2, 3, 5, \_\_, 13, 21, 34, \_\_, 89

2a .....

b .....

3 1, 3, 6, 10, \_\_, \_\_, \_\_, 36, 45

3a .....

b .....

4 1, 8, 27, \_\_, 125, 216, \_\_, 512

4a .....

b .....

5 Here is a list of numbers:

1, 2, 3, 4, 9, 27, 54

a Which numbers are prime?

5a .....

b Which numbers are factors of 18?

b .....

c Which numbers are multiples of 3?

c .....

d Which numbers are square numbers?

d .....

e Which numbers are cube numbers?

e .....

6 Here is a list of numbers:

1, 5, 31, 64, 75, 169, 960, 4918

a Which numbers are prime?

6a .....

b Which numbers are factors of 25?

b .....

c Which numbers are multiples of 15?

c .....

d Which numbers are square numbers?

d .....

e Which numbers are cube numbers?

e .....



# 10 Product of primes, highest common factor, lowest common multiple, reciprocals



1 Write 1386 as a product of primes. 1.....

2 Write 2058 as a product of primes. 2.....

3 Find: 3a.....

a the HCF fo 1386 and 2058 b.....

b the LCM of 1386 and 2058.

4 Write 336 as a product of primes. 4.....

5 Write 3780 as a product of primes. 5.....

6 Find: 6a.....

a the HCF of 336 and 3780 b.....

b the LCM of 336 and 3780.

7 What is the reciprocal of: 7a.....

a 16?

b  $\frac{7}{8}$ ? b.....

c -5? c.....



# 11 Trial and improvement

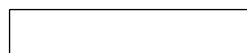

You must show all of your working.

1  $x^3 - 4x = 528$

Find the value of  $x$  correct to one decimal place using trial and improvement methods.

1 .....

2  $x^3 + 2x^2 = 546$

Find the value of  $x$  correct to one decimal place using trial and improvement methods.

2 .....



# 12 Equations

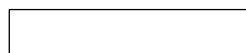

Give the answer to three significant figures where appropriate.

1  $a^2 = 6$  1.....

2  $\sqrt{c} = 20$  2.....

3  $3d^2 = 7.3$  3.....

4  $x^2 - 3 = 18.4$  4.....

5  $7a + 4(2a - 3) = 6$  5.....

6  $8(x + 2) = 5(3x - 6)$  6.....

7  $6.8a - 7 = 3.1a + 2$  7.....

8  $\frac{y}{4} - 2 = 7.5$  8.....

9  $6y - 7(3y + 4) = 6$  9.....

10  $5y - 2(6y - 7) = 0$  10.....

11  $\frac{3}{y} = 10$  11.....

12  $\frac{6}{5y} - 3 = 4$  12.....

13  $\frac{7}{4y} = 10$  13.....

14  $\frac{6}{y} = y$  14.....



## 13 Rewriting formulae

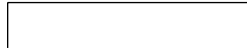

In each question, make A the subject.

1  $\sqrt{A} = C$  1 .....

2  $A^2 = D$  2 .....

3  $5A^2 = B$  3 .....

4  $3E - D = 4A - 5$  4 .....

5  $5A - 3C = 2A + 7C$  5 .....

6  $5C - 2A = 3C - 8A$  6 .....

7  $\frac{6A}{7} = 3Y$  7 .....

8  $A^2 - 7C = 4D$  8 .....

9  $\frac{C}{A} = B$  9 .....

10  $\frac{CD}{5A} = BE$  10 .....

11  $2D = \frac{C}{3A} + 7$  11 .....

12  $C = \frac{A + D}{4E}$  12 .....

13  $\frac{B}{D} = 3A^2C$  13 .....

14  $F = \frac{B + C}{A + D}$  14 .....

15  $5AC - 2Y = 3AD$  15 .....



# 14 Iteration

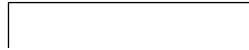

1 Here are some iteration formulae.  
Start with a value of  $x_1 = 5$ .

- i State whether the sequence converges or diverges.
- ii If it converges, state the limit correct to three decimal places.

a  $x_{n+1} = \frac{x_n + 3}{5}$

- 1a i .....
- ii .....

b  $x_{n+1} = \frac{x_n}{4} + 2$

- b i .....
- ii .....

c  $x_{n+1} = \frac{5}{x_n^3 - 2}$

- c i .....
- ii .....

2 Solve the following quadratic equations by iterative methods.  
You will need two iterative formulae for each question.

Show:

- i the iterative formulae
- ii the solutions.

a  $x^2 + 5x + 6 = 0$

- iterative formula 2a i .....
- solution ii .....
- iterative formula i .....
- solution ii .....

b  $x^2 - 3x = 10$

- iterative formula b i .....
- solution ii .....
- iterative formula i .....
- solution ii .....



## 15 Direct and inverse variation

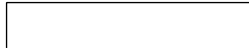

- 1 a is proportional to c.  
 a = 12 when c = 4
- a Write out the equation connecting a and c (ie the k equation). 1a.....
- b Find the value of a when c = 5. b.....
- c Find the value of c when a = 21. c.....
- 
- 2 x is proportional to  $y^3$ .  
 x = 135 when y = 3
- a Write out the equation connecting x and y (ie the k equation). 2a.....
- b Find the value of x when y = 7. b.....
- c Find the value of y when x = 320. c.....
- 
- 3 p is inversely proportional to q.  
 p = 1.6 when q = 5
- a Write out the equation connecting p and q (ie the k equation). 3a.....
- b Find the value of p when q = 20. b.....
- c Find the value of q when p = 2. c.....
- 
- 4 M is inversely proportional to  $R^3$ .  
 M = 8 when R = 5
- a Write out the equation connecting M and R (ie the k equation). 4a.....
- b Find the value of M when R = 10. b.....
- c Find the value of R when M = 15.625. c.....





## 16 Using algebraic formulae



In each question find the value of  $y$ , correct to six significant figures where appropriate.  
Use efficient calculator methods.

$$a = 2.72 \quad b = \frac{3}{7} \quad c = \frac{2}{9} \quad d = -7.15 \quad e = 6.2749$$

$$1 \quad y = \frac{4a - 6b}{d^2 - a^2} \quad 1 \dots\dots\dots \square$$

$$2 \quad y = \frac{3c^2(ab + d)}{bcd - a^2} \quad 2 \dots\dots\dots \square$$

$$3 \quad y = 3e^5 + 2e^3 - 6e \quad 3 \dots\dots\dots \square$$

$$4 \quad y = \frac{a\sqrt{cd}}{e - d} \quad 4 \dots\dots\dots \square$$

$$5 \quad \sqrt{\frac{6ad}{5bc}} \quad 5 \dots\dots\dots \square$$

$$6 \quad \sqrt{\frac{a + b - d}{3cd}} \quad 6 \dots\dots\dots \square$$

$$7 \quad \frac{c^2 + e^2}{d^4 - c^3} \quad 7 \dots\dots\dots \square$$



## 17 Rules for indices (powers)

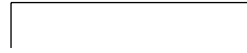

1 Simplify:

- |                          |                                  |
|--------------------------|----------------------------------|
| a $a^4 \times a^7$       | 1a..... <input type="checkbox"/> |
| b $a \times a^6$         | b..... <input type="checkbox"/>  |
| c $a^4 \times a^{-7}$    | c..... <input type="checkbox"/>  |
| d $a^{-2} \times a^{-6}$ | d..... <input type="checkbox"/>  |
| e $3a^2 \times 4a^3$     | e..... <input type="checkbox"/>  |
| f $a^8 \div a^2$         | f..... <input type="checkbox"/>  |
| g $a^{10} \div a^5$      | g..... <input type="checkbox"/>  |
| h $16a^{12} \div 4a^3$   | h..... <input type="checkbox"/>  |
| i $a^{-5} \div a^2$      | i..... <input type="checkbox"/>  |
| j $a^{-6} \div a^{-2}$   | j..... <input type="checkbox"/>  |
| k $a^8 \div a^{-4}$      | k..... <input type="checkbox"/>  |

2 Evaluate:

- |                  |                                  |
|------------------|----------------------------------|
| a $7^4$          | 2a..... <input type="checkbox"/> |
| b $343^{1/3}$    | b..... <input type="checkbox"/>  |
| c $8^0$          | c..... <input type="checkbox"/>  |
| d $\sqrt[5]{32}$ | d..... <input type="checkbox"/>  |
| e $2^{-3}$       | e..... <input type="checkbox"/>  |

3 Simplify:

- |                            |                                  |
|----------------------------|----------------------------------|
| a $(a^7)^3$                | 3a..... <input type="checkbox"/> |
| b $a^{2/5} \times a^{1/3}$ | b..... <input type="checkbox"/>  |
| c $a^{1/4} \div a^{1/6}$   | c..... <input type="checkbox"/>  |
| d $a^{1/2} \div a^{-1/4}$  | d..... <input type="checkbox"/>  |



## 18 Expansion of brackets

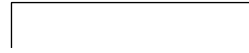

Simplify:

1  $3a^2 \times 5a^4$  1 .....

2  $2a^3c^5 \times 3a^4c$  2 .....

3  $12a^3cd^4 \div 3acd^2$  3 .....

4  $(2a^3)^4$  4 .....

Expand:

5  $(4a + 2)(3a - 5)$  5 .....

6  $(5a - 3)(2a + 6)$  6 .....

7  $(6a - 4)(5a - 2)$  7 .....

8  $(3a - 2)^2$  8 .....

9  $4(3y - 6)$  9 .....

10  $3a(4a + 2y^3)$  10 .....

11  $3a^3(2a^2 + 7a)$  11 .....

12  $-6a(4a^3 - 3c^2)$  12 .....

13  $(3a + 5)(2a - 6)$  13 .....

14  $(5y - 3)(4y - 6)$  14 .....

15  $(3a + 4)(2a + 5)$  15 .....

16  $(4y - 7)^2$  16 .....



## 19 Factorisation – 1

Factorise:

1  $4a - 10$  1.....

2  $16x + 12y$  2.....

3  $36a - 27x$  3.....

4  $18a - 27c + 9y$  4.....

5  $5y^2 - 7y$  5.....

6  $12y^2 - 20y$  6.....

7  $16a^8 + 10a^5$  7.....

8  $10a^3c^2 - 8ac$  8.....

9  $25a^3c^2y - 10a^5cy^3$  9.....

10  $60acd - 48a^2d$  10.....

11  $15a^3 - 25a^2c + 10a^3y$  11.....

12  $8a^8 - 6a^5 + 10a^3$  12.....

## 20 Factorisation – 2

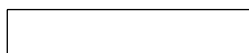

Factorise:

1  $x^2 + 8x + 15$  1.....

2  $x^2 + 11x + 18$  2.....

3  $x^2 - 9x + 14$  3.....

4  $x^2 - 9x + 20$  4.....

5  $x^2 + 6x - 16$  5.....

6  $x^2 - 7x + 12$  6.....

7  $y^2 - 9y - 10$  7.....

8  $a^2 + 5a - 24$  8.....



## 21 Factorisation – 3



Factorise:

1  $x^2 + 7x + 10$  1 .....

2  $x^2 + 11x + 28$  2 .....

3  $x^2 - 10x + 21$  3 .....

4  $x^2 - 2x - 15$  4 .....

5  $a^2 + a - 20$  5 .....

6  $y^2 - 10y + 16$  6 .....

7  $y^2 + 8y + 7$  7 .....

8  $a^2 - a - 12$  8 .....



## 22 Factorisation – 4

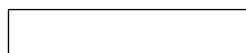

Solve the following quadratics by factorisation:

1  $x^2 + 10x + 9 = 0$

$x = \dots\dots\dots$

$x = \dots\dots\dots$

2  $x^2 - 10x + 16 = 0$

$x = \dots\dots\dots$

$x = \dots\dots\dots$

3  $y^2 + 2y - 15 = 0$

$y = \dots\dots\dots$

$y = \dots\dots\dots$

4  $y^2 - y - 30 = 0$

$y = \dots\dots\dots$

$y = \dots\dots\dots$

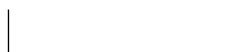

## 23 Factorisation – 5

1 Factorise  $y^2 - 49$

1 .....

2 Factorise  $16a^2 - 81$

2 .....

3 Solve  $x^2 + 12x + 32 = 0$  by factorisation.

3  $x =$  .....

$x =$  .....

4 Solve  $x^2 - 11x + 24 = 0$  by factorisation.

4  $x =$  .....

$x =$  .....

5 Solve  $x^2 + 5x - 14 = 0$  by factorisation.

5  $x =$  .....

$x =$  .....

6 Solve  $x^2 - x - 42 = 0$  by factorisation.

6  $x =$  .....

$x =$  .....



## 24 Solving quadratic equations

For  $ax^2 + bx + c = 0$

$$x = \frac{-b \pm \sqrt{b^2 - 4ac}}{2a}$$

1 Solve  $x^2 + 3x - 3 = 0$

1  $x = \dots\dots\dots$

$x = \dots\dots\dots$

2 Solve  $3x^2 - 4x - 3 = 0$

2  $x = \dots\dots\dots$

$x = \dots\dots\dots$

3 Solve  $-2a^2 + 5a + 9 = 0$

3  $a = \dots\dots\dots$

$a = \dots\dots\dots$

4 Solve  $8y^2 - 6y - 10 = 0$

4  $y = \dots\dots\dots$

$y = \dots\dots\dots$

5 Solve  $x^2 = 12 - 3x$

5  $x = \dots\dots\dots$

$x = \dots\dots\dots$

6 Solve  $8x^2 - 30x = -10$

6  $x = \dots\dots\dots$

$x = \dots\dots\dots$

# 25 Simultaneous equations: Solving using algebra – 1

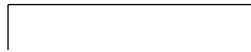

Solve the following simultaneous equations:

1  $3x + 4y = 18$

$x = \dots\dots\dots$

$2x + 5y = 19$

$y = \dots\dots\dots$

2  $2x + 3y = 9$

$x = \dots\dots\dots$

$5x - 4y = 11$

$y = \dots\dots\dots$

3  $4a - 3c = -4$

$a = \dots\dots\dots$

$5a - 2c = 2$

$c = \dots\dots\dots$

4  $5x + y = -6$

$x = \dots\dots\dots$

$3x - 3y = -18$

$y = \dots\dots\dots$

5  $2x = 10 - 3y$

$x = \dots\dots\dots$

$3x + 19 = 4y$

$y = \dots\dots\dots$



## 26 Simultaneous equations: Solving using algebra – 2

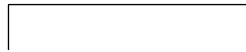

Solve the following simultaneous equations:

1  $2x + 3y = 18$   $x = \dots\dots\dots \square$   
 $5x + 2y = 23$   $y = \dots\dots\dots \square$

2  $4x + 2y = -2$   $x = \dots\dots\dots \square$   
 $3x - 7y = 41$   $y = \dots\dots\dots \square$

3  $5x + 6y = -51$   $x = \dots\dots\dots \square$   
 $3x - 2y = 3$   $y = \dots\dots\dots \square$

4  $2a - 3c = -1.8$   $a = \dots\dots\dots \square$   
 $3a - 5c = -4.4$   $c = \dots\dots\dots \square$

5  $6a + 3y = 51$   $a = \dots\dots\dots \square$   
 $4a + 1 = 5y$   $y = \dots\dots\dots \square$



## 27 Simplifying algebraic fractions – 1

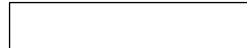

Simplify:

$$1 \quad \frac{10a - 15}{25a + 35} \quad 1 \dots\dots\dots \square$$

$$2 \quad \frac{12a - 8}{15a - 10} \quad 2 \dots\dots\dots \square$$

$$3 \quad \frac{x^2 - x - 20}{x^2 - 8x + 15} \quad 3 \dots\dots\dots \square$$

$$4 \quad \frac{x^2 - 5x - 14}{x^2 - x - 6} \quad 4 \dots\dots\dots \square$$

$$5 \quad \frac{3a^3c^2}{5ac} \times \frac{2a}{3c^3} \quad 5 \dots\dots\dots \square$$

$$6 \quad \frac{6a^5c}{5ac^4} \times \frac{4a^3}{9ac^4} \quad 6 \dots\dots\dots \square$$

$$7 \quad \frac{4a^3}{15ac} \div \frac{2a^3c^2}{3c^3} \quad 7 \dots\dots\dots \square$$

$$8 \quad \frac{10c^3d^2}{3ac^2} \div \frac{5d^3}{7cd^2} \quad 8 \dots\dots\dots \square$$



## 28 Simplifying algebraic fractions – 2

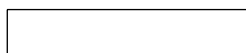

Simplify:

1  $\frac{3a + 4}{2} + \frac{5a + 2}{3}$  1 .....

2  $\frac{6y - 2}{5} + \frac{2y - 3}{4}$  2 .....

3  $\frac{3c - 2}{4} - \frac{2c - 5}{3}$  3 .....

4  $\frac{5c - 4}{7} - \frac{3c + 2}{3}$  4 .....

5  $\frac{2(c - 3)}{7} + \frac{3(4c - 2)}{2}$  5 .....

6  $\frac{3(a - 5)}{6} - \frac{5(a - 3)}{15}$  6 .....

7  $\frac{3}{a + 2} + \frac{4}{a - 3}$  7 .....

8  $\frac{5}{a + 5} - \frac{2}{a + 1}$  8 .....



# 29 Drawing lines

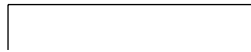

Which letters represent the following lines:

1  $x = 4$  1.....

2  $y = 4$  2.....

3  $x = 0$  3.....

4  $y = 0$  4.....

5  $y = x$  5.....

6  $y = -x$  6.....

7  $y = x - 3$  7.....

8  $y = -x - 3$  8.....

9 Complete this table of values and draw the graph of  $y = -\frac{1}{2}x^2 + 4$ .

x	-4	-3	-2	-1	0	1	2	3	4
y									

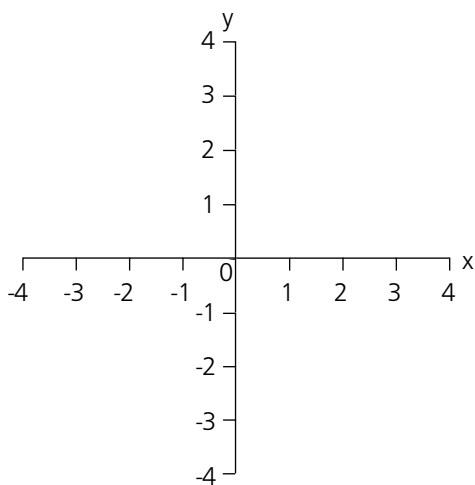

# 30 Simultaneous equations: Solving by drawing a graph – 1

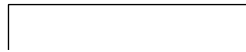

Solve these simultaneous equations by drawing a graph:

1  $y + 2x = 7$   
 $2y + x = 8$

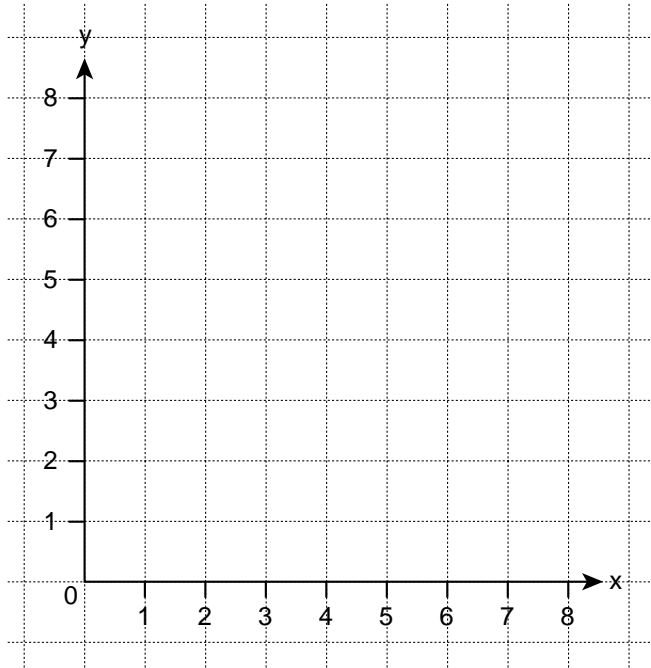

$x =$  .....

$y =$  .....

2  $2y + 4x = 6$   
 $2y - x = -4$

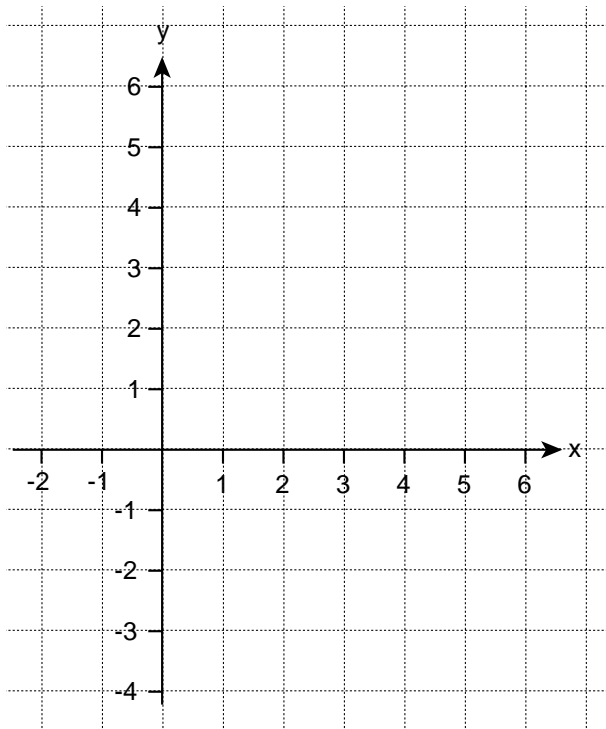

$x =$  .....

$y =$  .....



# 31 Simultaneous equations: Solving by drawing a graph – 2

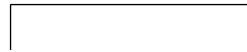

Solve these simultaneous equations by drawing a graph:

1  $y + 2x = 4$

$2y + x = 5$

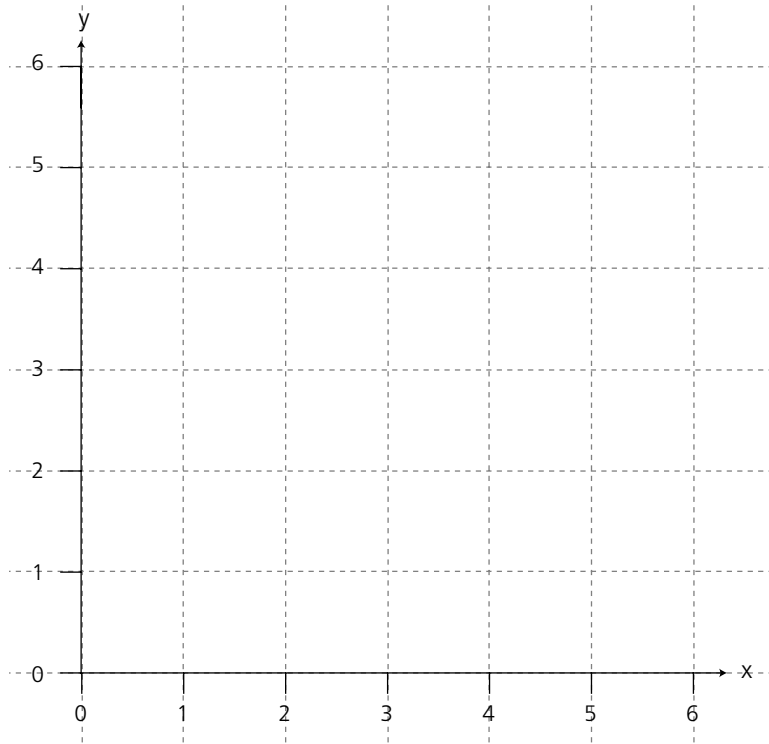

$x = \dots\dots\dots$

$y = \dots\dots\dots$

2  $y - 2x = -4$

$y + 4x = 2$

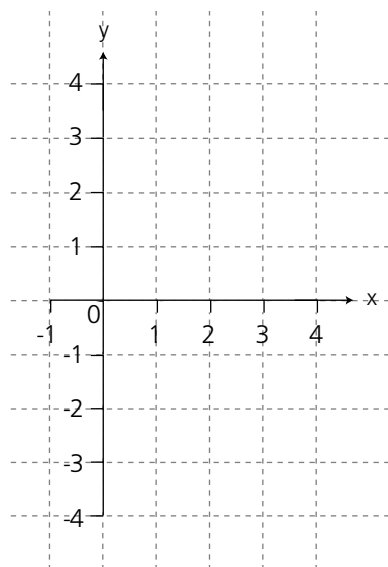

$x = \dots\dots\dots$

$y = \dots\dots\dots$





### 32 Solving equations using graphical methods

Complete this table and draw the graph  $y = x^2 + x$ .

x	-2	-1	$-\frac{1}{2}$	0	$\frac{1}{2}$	1	2
y							

Complete this table and draw the graph  $y = x + 2$ .

x	-2	-1	$-\frac{1}{2}$	0	$\frac{1}{2}$	1	2
y							

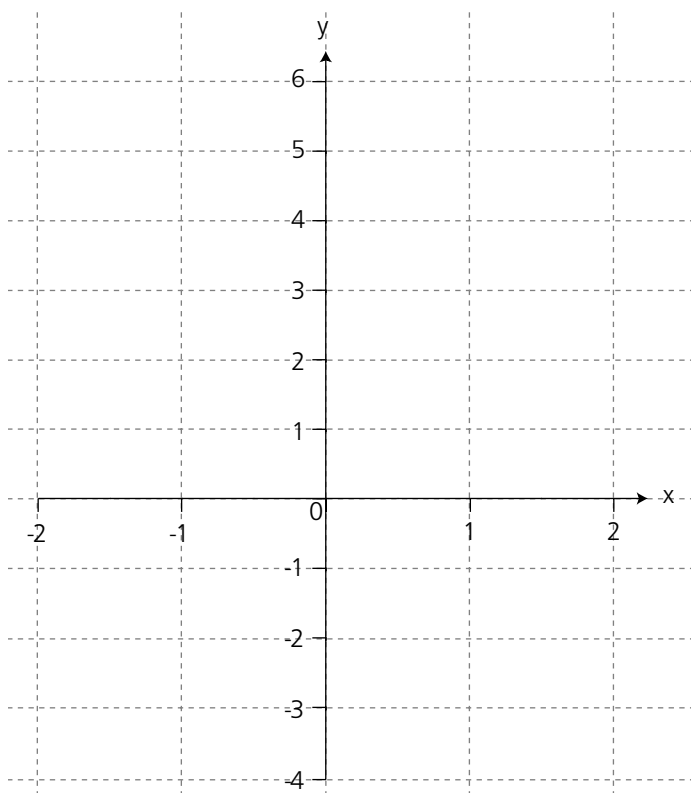

Use your graphs to solve:

1  $x^2 + x = 1$

1  $x = \dots\dots\dots$

$x = \dots\dots\dots$

2  $x^2 + x = x + 2$

2  $x = \dots\dots\dots$

$x = \dots\dots\dots$

# 33 The straight line equation – 1

## $y = mx + c$

- a What are the gradients of the four lines shown below?  
 b What are the equations of the four lines shown below?

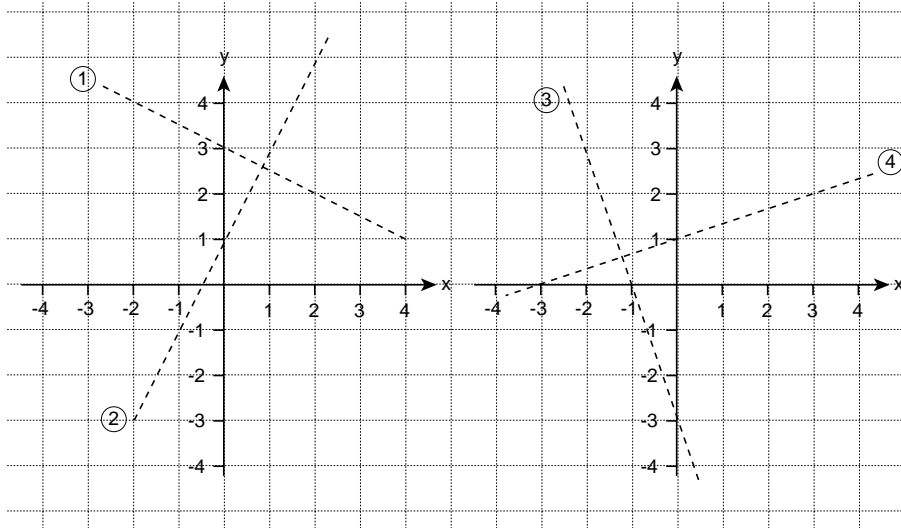

- 1a .....   
 b  $y =$  .....   
 2a .....   
 b  $y =$  .....   
 3a .....   
 b  $y =$  .....   
 4a .....   
 b  $y =$  .....

- 5 What is the:  
 a gradient  
 b equation of the line which passes through the points (-4, -3) and (4, 1)?

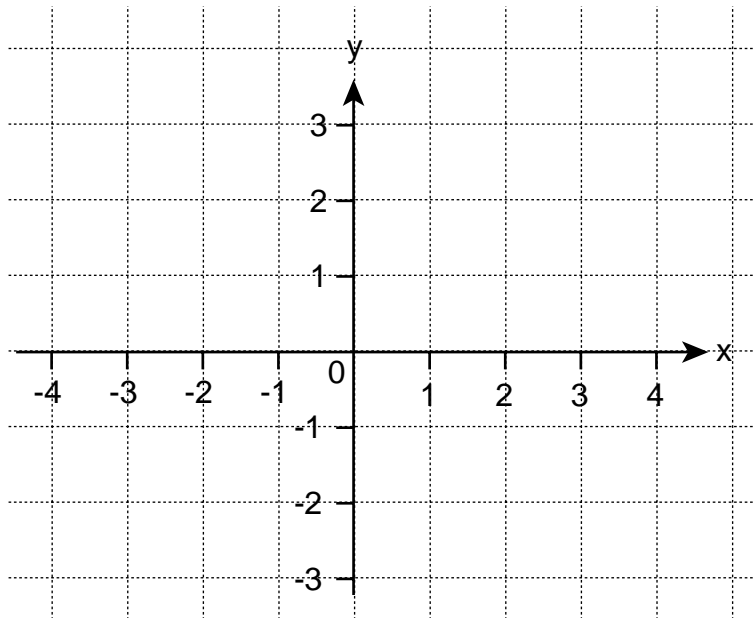

- 5a .....   
 b  $y =$  .....

### 34 The straight line equation – 2

$y = mx + c$

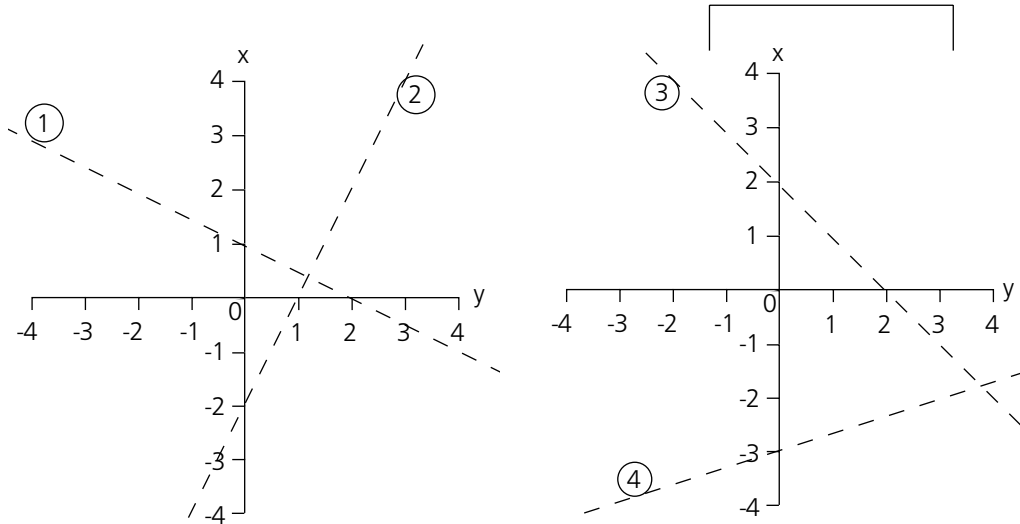

- a What are the gradients of the four lines shown above?
- b What are the equations of the four lines shown above?

1a .....

b  $y =$  .....

2a .....

b  $y =$  .....

3a .....

b  $y =$  .....

4a .....

b  $y =$  .....

- 5 What is the:
  - a gradient
  - b equation of the line which passes through the points (2, -1) and (6, 1)?

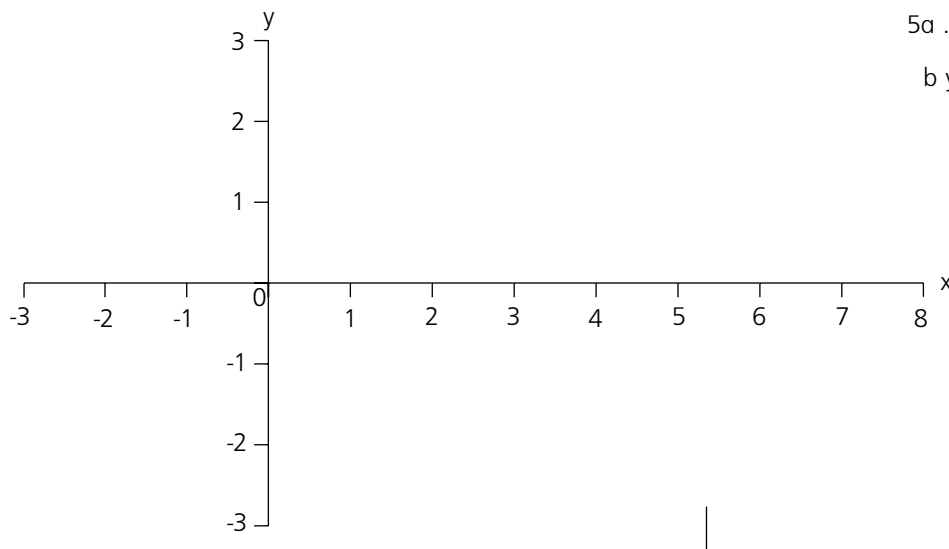

5a .....

b  $y =$  .....

# 35 Using tangents to find gradients

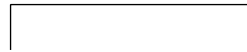

1 Draw the graph of  $y = \frac{1}{2} x^2$  for values  $-3 \leq x \leq 3$ .

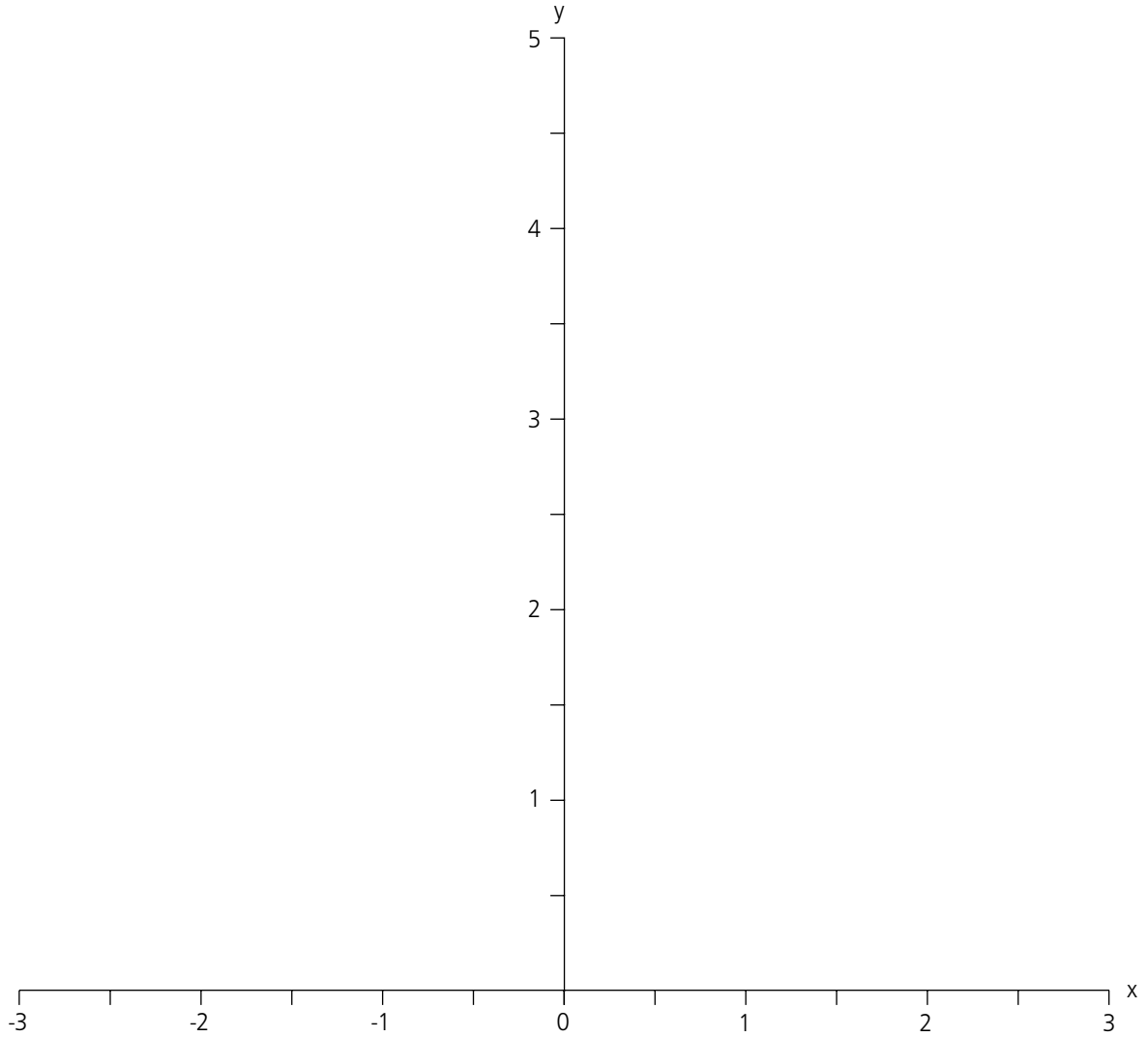

x	-3	-2	-1	0	1	2	3	4
y								

Table

By drawing suitable lines, find the gradient at:

a  $x = 2$

a.....

b  $x = 1$

b.....

c  $x = -0.5$

c.....

d  $x = -1.5$

d.....



### 36 Expressing general rules in symbolic form – 1

1 This table shows the price of gas:

Number of units used	100	200	300	400
Price (£)	35	55	75	95

a Show this information on the graph.

1a

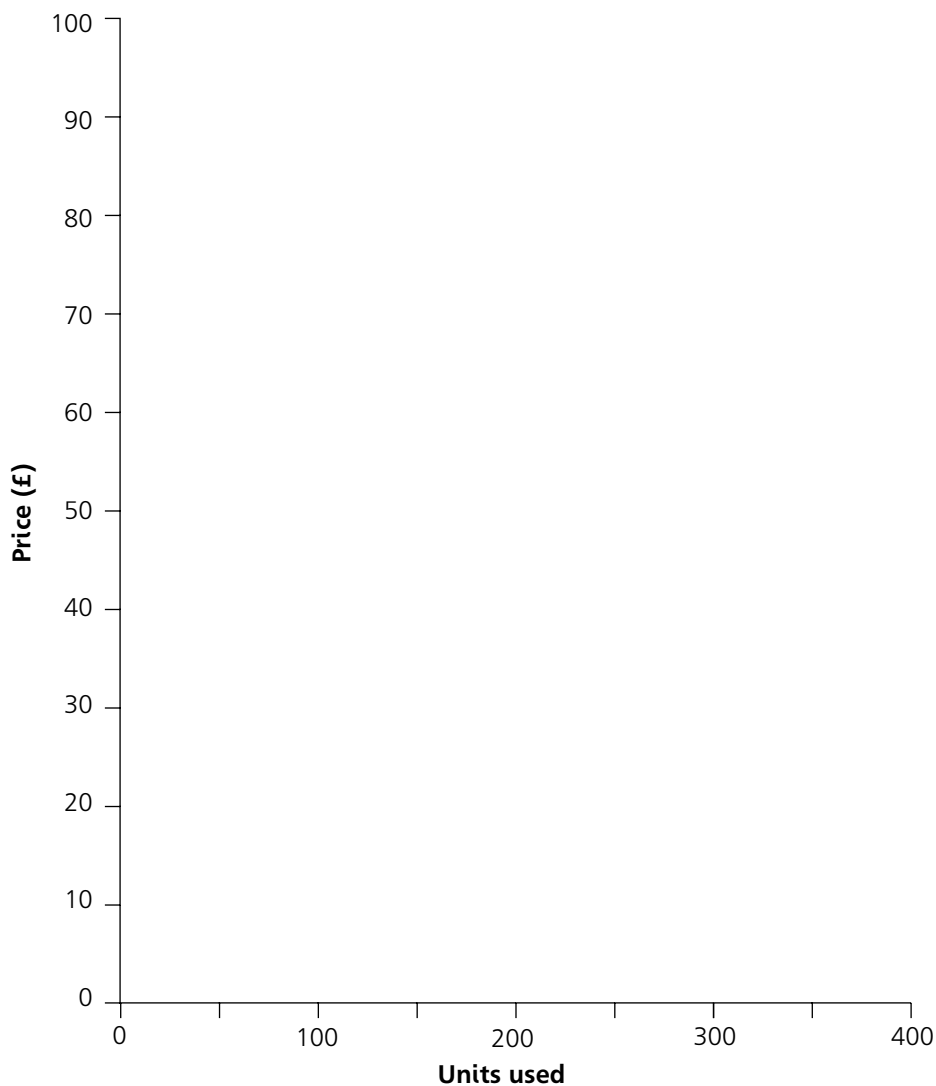

- b Find a formula connecting price (P) and number of units (N) used.      b  $P = £( \quad N + \quad )$
- c Use your formula to find the price when 3000 units are used.      c.....
- d Use your formula to find the number of units used when the price is £62.40.      d.....

### 37 Expressing general rules in symbolic form – 2



1 Two variables, a and b, are connected by the equation  $y = ax^2 + b$ .

Here are some values of x and y:

x	2	4	6
y	4	7	12

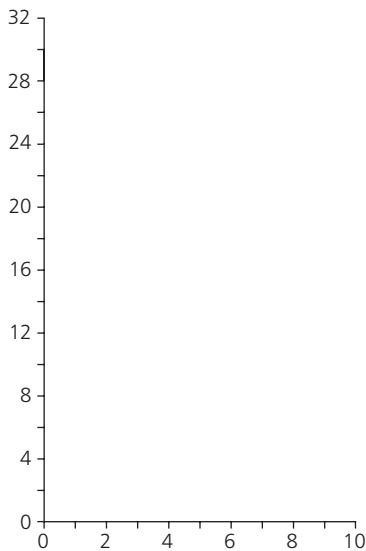

- a Find the value of a.
- b Find the value of b.

1a.....

b.....

2 The variables, a and b, are connected by the equation  $y = ax^3 + b$ .

Here are some values of x and y:

x	1	2
y	1	4.5

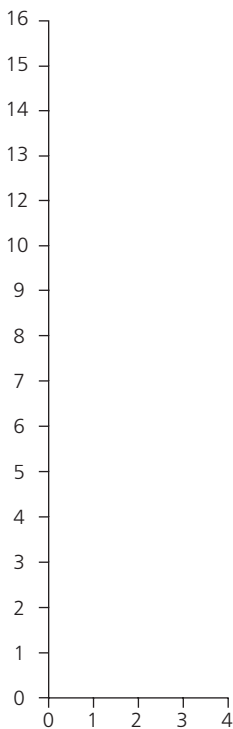

- a Find the value of a.
- b Find the value of b.
- c What is the value of y when x = 4?

2a.....

b.....

c.....



# 38 Inequalities – 1

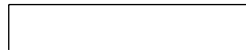

Describe the shaded regions:

1

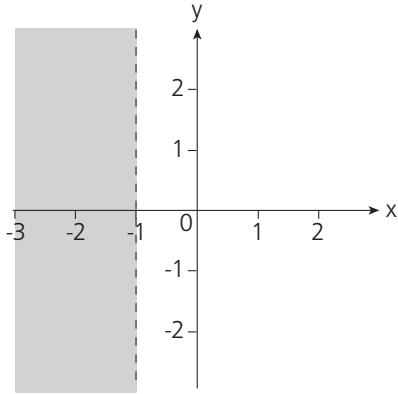

1.....

2

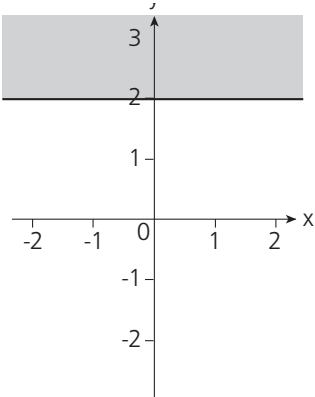

2.....

3

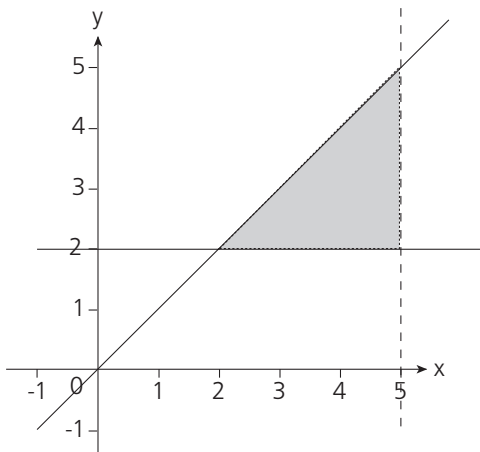

3.....

.....

.....



## 39 Inequalities – 2

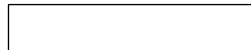

Solve these inequalities:

1  $7x > 42$  1.....

2  $5x - 4 \leq 26$  2.....

3  $x^2 \geq 64$  3.....

4  $23 \geq 3x + 5 > -4$  4.....

5  $-5x > 45$  5.....

6  $-7x \leq -56$  6.....

7 Describe the shaded regions:

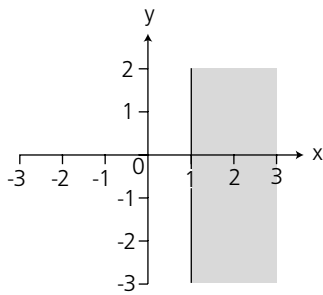

7.....

8

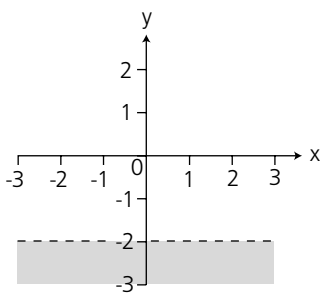

8.....

9

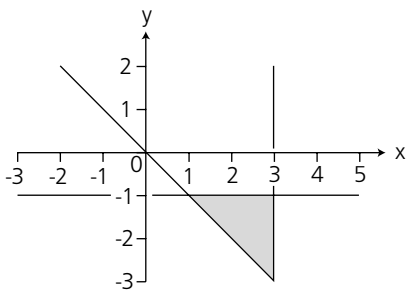

9.....

.....

.....





# 40 Drawing graphs - 1

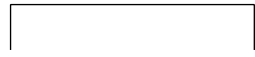

Label the following graphs using the letters shown below.

Choose from:

- a  $y = 2x + 1$       b  $y = -2x + 1$       c  $y = -2x - 1$       d  $y = 2x - 1$       e  $y = 2x$
- f  $y = 2x^2 + 1$       g  $y = -2x^2 + 1$       h  $y = 2x^2 - 1$       i  $y = -2x^2 - 1$       j  $y = -2x$
- k  $y = x^3 + 1$       l  $y = -x^3 + 1$       m  $y = x^3 - 1$       n  $y = -x^3 - 1$       o  $y = x^3$
- p  $y = -1/x$       q  $y = 1/x$

1

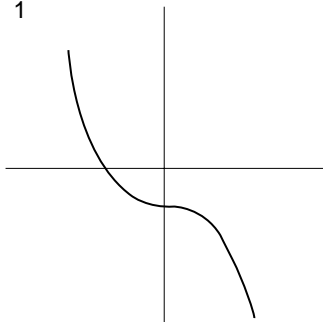

2

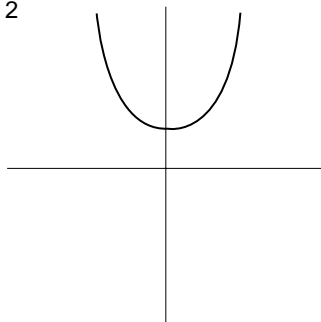

3

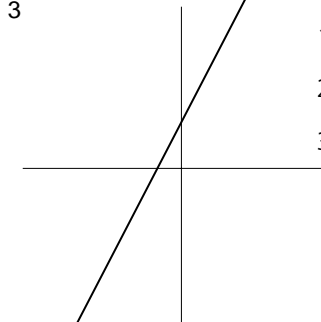

- 1.....
- 2.....
- 3.....

4

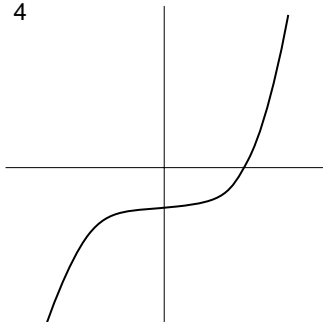

5

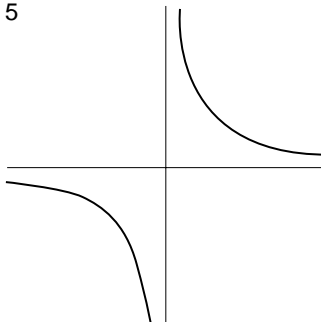

6

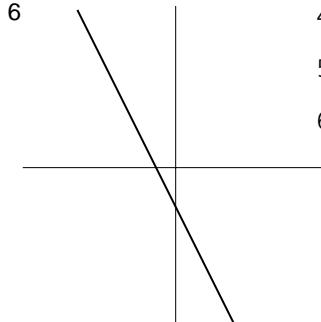

- 4.....
- 5.....
- 6.....

7

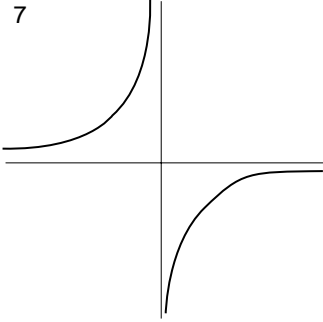

8

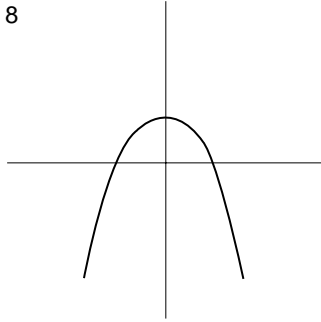

9

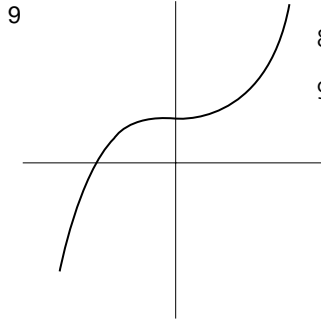

- 7.....
- 8.....
- 9.....



## 41 Drawing graphs – 2

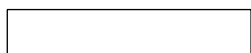

Label the following graphs using the letters shown below.

Choose from:

- |                       |                        |                        |
|-----------------------|------------------------|------------------------|
| a $y = 2x^2 - 1$      | b $y = x$              | c $y = 3x + 1$         |
| d $y = x^3$           | e $y = -2x^2 - 1$      | f $y = 1/x$            |
| g $y = 3$             | h $y = x^3 - 2x^2 + 1$ | i $y = -x^3 - 2x - 1$  |
| j $y = 5x - 1$        | k $y = x^2$            | l $y = x^3 - 2x^2 - 1$ |
| m $y = -x^3 + 2x + 1$ | n $y = -5x + 1$        | o $y = -1/x$           |
| p $x = 3$             |                        |                        |

<p>1</p>	<p>2</p>	<p>3</p>	<p>1..... <input type="checkbox"/></p> <p>2..... <input type="checkbox"/></p> <p>3..... <input type="checkbox"/></p>
----------	----------	----------	----------------------------------------------------------------------------------------------------------------------

<p>4</p>	<p>5</p>	<p>6</p>	<p>4..... <input type="checkbox"/></p> <p>5..... <input type="checkbox"/></p> <p>6..... <input type="checkbox"/></p>
----------	----------	----------	----------------------------------------------------------------------------------------------------------------------

<p>7</p>	<p>8</p>	<p>9</p>	<p>7..... <input type="checkbox"/></p> <p>8..... <input type="checkbox"/></p> <p>9..... <input type="checkbox"/></p>
----------	----------	----------	----------------------------------------------------------------------------------------------------------------------

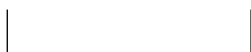

## 42 Sketching graphs – 1

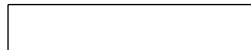

1 This is the graph of  $y = f(x)$ .

Draw the graph of  $y = f(x - 1)$ .

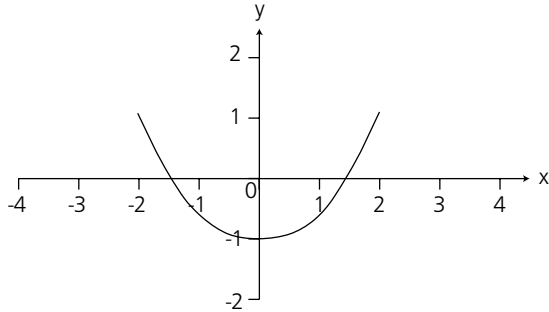

1

2 This is the graph of  $y = f(x)$ .

Draw the graph of  $y = f(x) + 1$ .

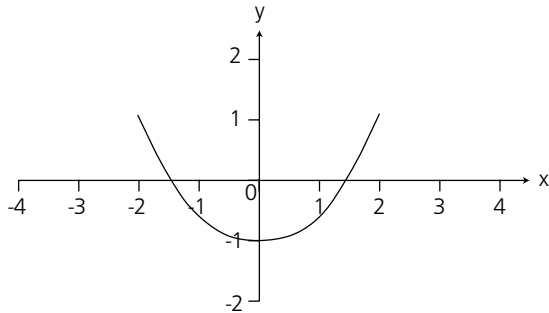

2

3 This is the graph of  $y = f(x)$ .

Draw the graph of  $y = \frac{1}{2}f(x)$ .

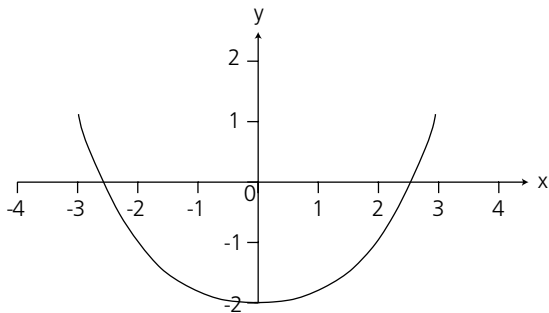

3

4 This is the graph of  $y = \frac{1}{2}x$ .

Draw the graph of  $y = \frac{1}{2}x - 1$ .

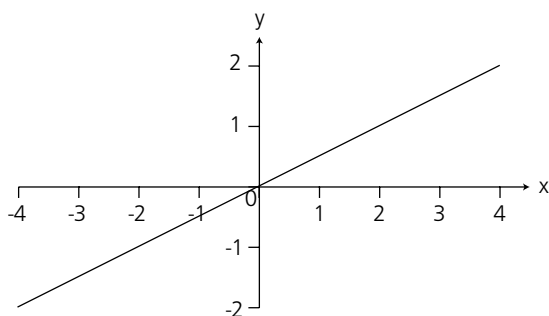

4



### 43 Sketching graphs – 2

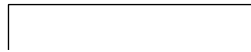

1 This is the graph of  $y = f(x)$ .

Draw the graph of  $y = f(x + 1)$ .

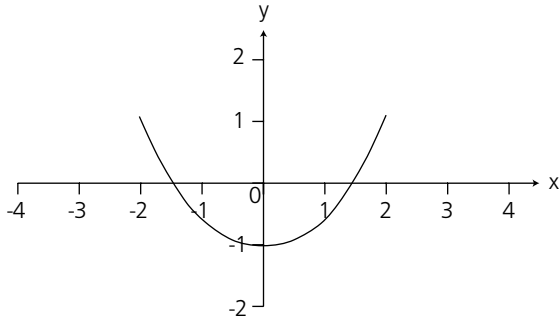

1

2 This is the graph of  $y = f(x)$ . Draw the graph of  $y = f(1/2 x)$ .

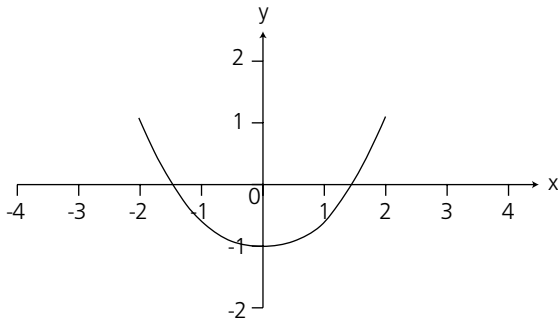

2

3 This is the graph of  $y = \cos(x)$ . Draw the graph of  $y = 3\cos(x)$ .

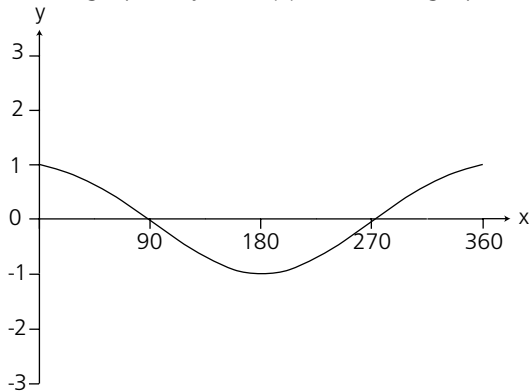

3

4 This is the graph of  $y = \cos(x)$ . Draw the graph of  $y = \cos(2x)$ .

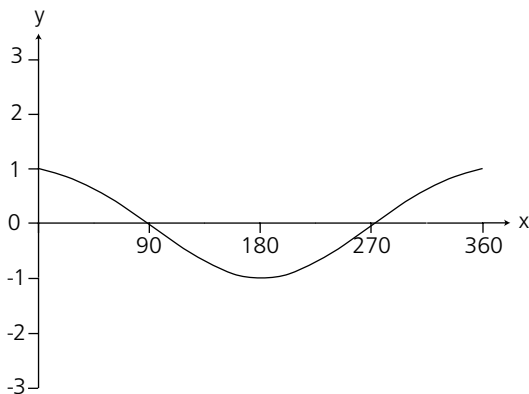

4



# 44 Speed, time and distance graphs

This graph shows the journeys made by two cyclists, A and B.

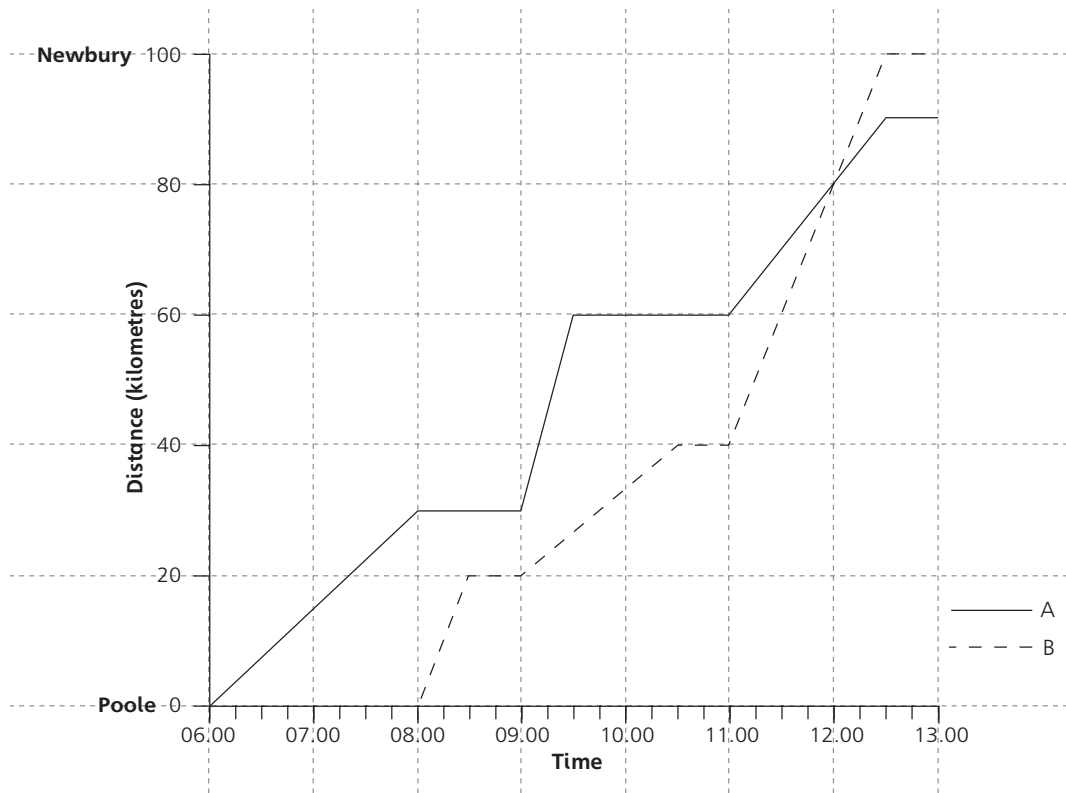

- 1 What time did cyclist A start her journey? 1.....
- 2 What was the speed of cyclist A between 06.00 and 08.00? 2.....
- 3 How far was cyclist A from Newbury at 12.30? 3.....
- 4 a Between which times did cyclist A travel fastest? 4a.....
- b How did you decide? b.....
- c What was the speed of cyclist A at this time? c.....
- 5 What was the speed of cyclist B at:
  - a 10.00? 5a.....
  - b 08.15? b.....
  - c 12.00? c.....
- 6 What time did cyclist B arrive in Newbury? 6.....
- 7 What was the total time taken by cyclist B for the journey from Poole to Newbury? 7.....
- 8 What happened at 12.00? 8.....

# 45 Area under a curve

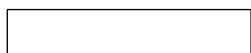

1 This graph shows the speed of a car during a period of 15 seconds.

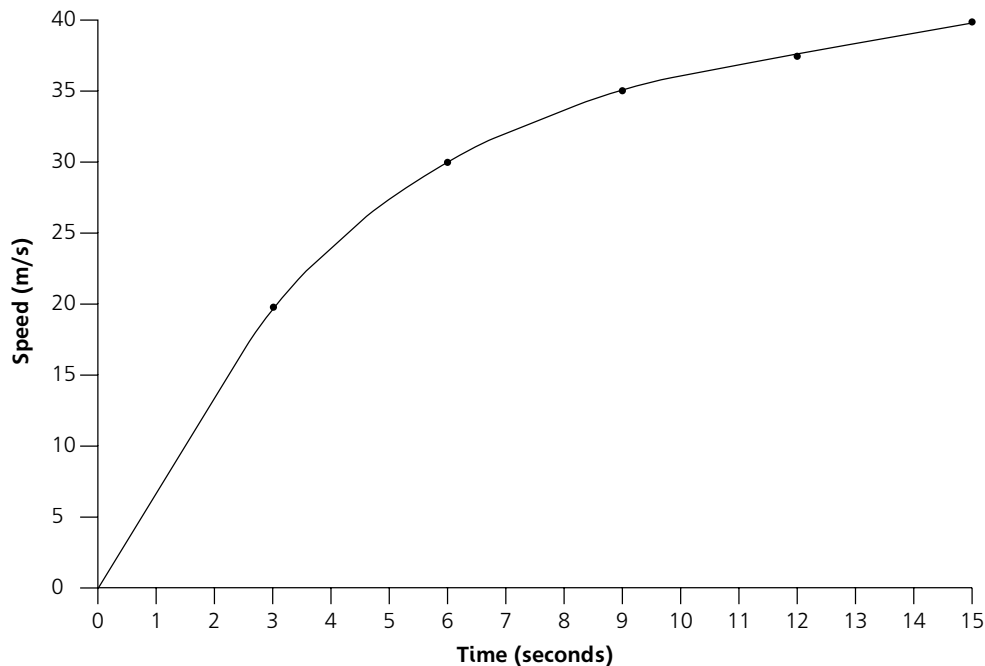

Estimate the total distance travelled by dividing the area under the curve into five trapezia.

1.....

2 This graph shows the speed of a train in the last 12 seconds of its journey.

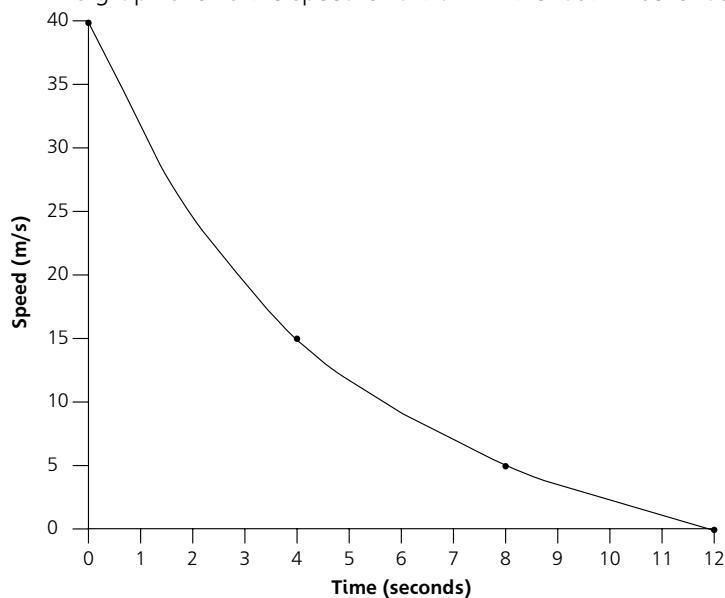

a Estimate the total distance travelled by dividing the area under the curve into three trapezia.

2a.....

b Is the actual distance travelled by the train more or less than your estimate?

b.....



# 46 Intersecting and parallel lines

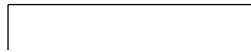

Find the missing angles in these diagrams:

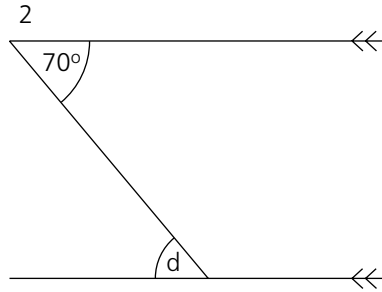
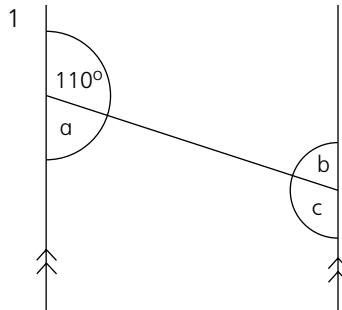

1 a = .....

b = .....

c = .....

2 d = .....

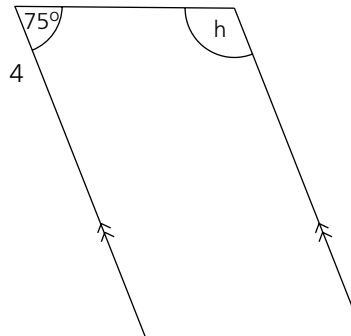
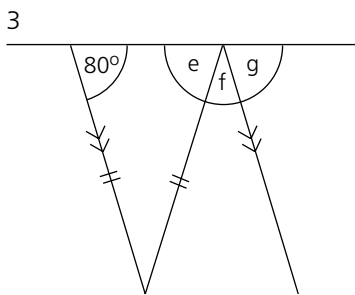

3 e = .....

f = .....

g = .....

4 h = .....

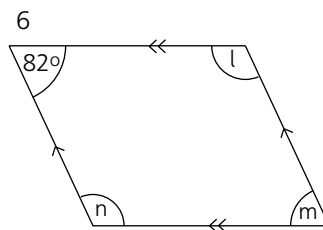
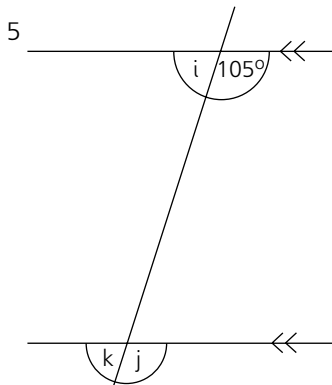

5 i = .....

j = .....

k = .....

6 l = .....

m = .....

n = .....

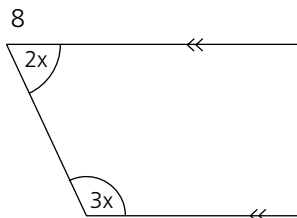
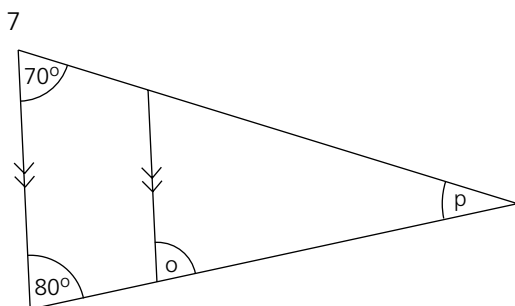

7 o = .....

p = .....

8 2x = .....

3x = .....



# 47 Bearings – 1

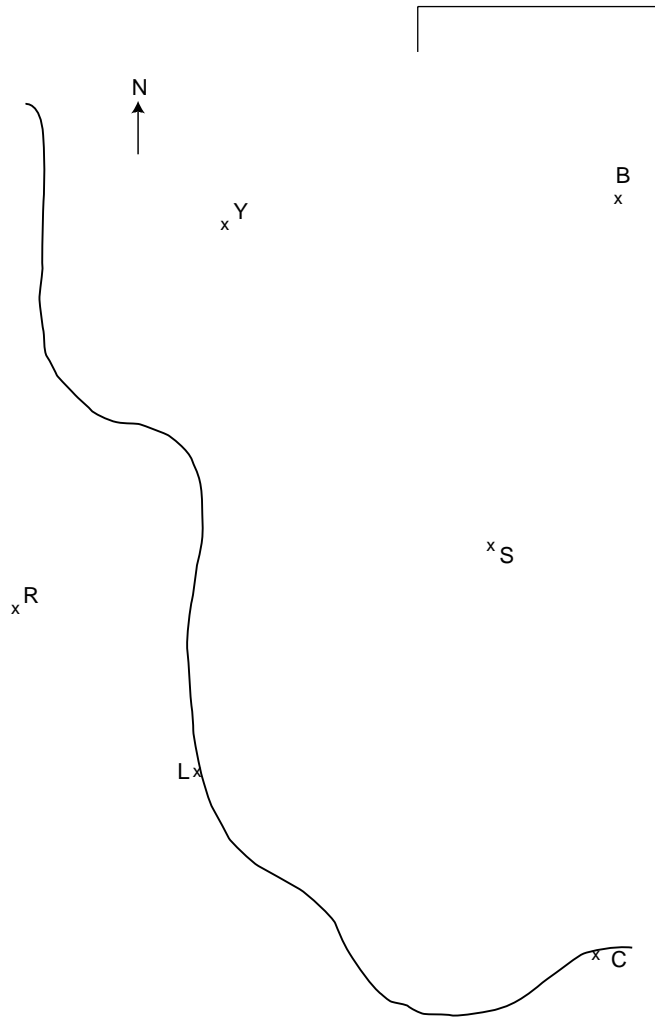

**Key**

- C is a footbridge
- L is a dam
- R is a church
- S is a farm
- Y is a village
- B is a town

What are the bearings of:

- |              |         |                          |
|--------------|---------|--------------------------|
| 1 S from B?  | 1.....  | <input type="checkbox"/> |
| 2 C from Y?  | 2.....  | <input type="checkbox"/> |
| 3 Y from C?  | 3.....  | <input type="checkbox"/> |
| 4 B from R?  | 4.....  | <input type="checkbox"/> |
| 5 R from B?  | 5.....  | <input type="checkbox"/> |
| 6 L from R?  | 6.....  | <input type="checkbox"/> |
| 7 R from L?  | 7.....  | <input type="checkbox"/> |
| 8 L from C?  | 8.....  | <input type="checkbox"/> |
| 9 Y from R?  | 9.....  | <input type="checkbox"/> |
| 10 R from Y? | 10..... | <input type="checkbox"/> |





# 48 Bearings – 2

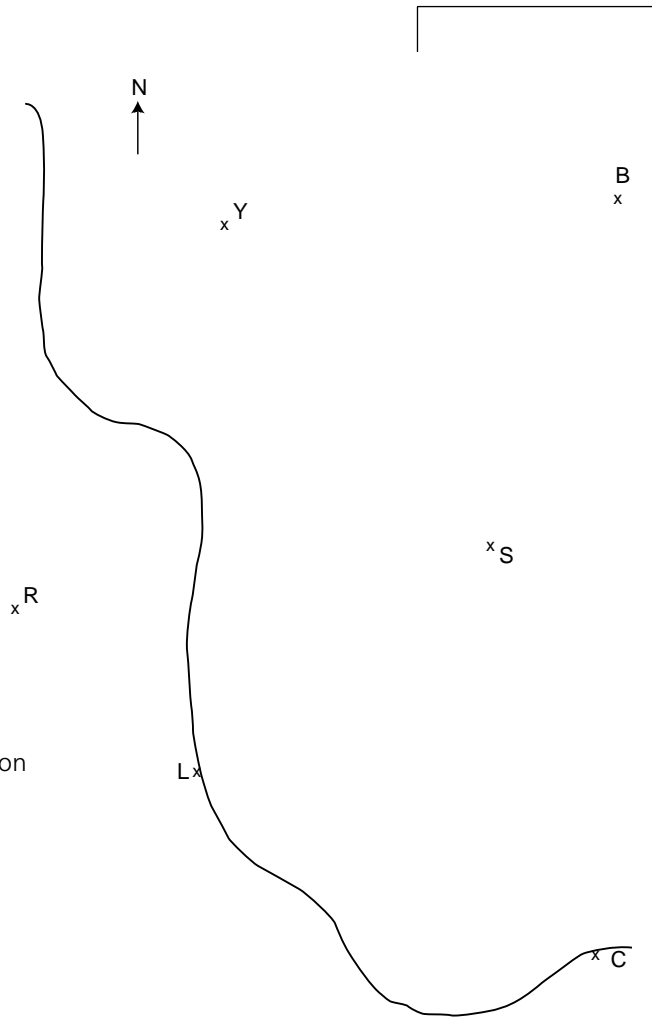

**Key**

- C is a coastguard station
- L is a lighthouse
- R is a radio mast
- S is a ship
- Y is a yacht
- B is a boat

What are the bearings of:

- |              |         |                          |
|--------------|---------|--------------------------|
| 1 B from L?  | 1.....  | <input type="checkbox"/> |
| 2 B from S?  | 2.....  | <input type="checkbox"/> |
| 3 B from C?  | 3.....  | <input type="checkbox"/> |
| 4 Y from B?  | 4.....  | <input type="checkbox"/> |
| 5 S from C?  | 5.....  | <input type="checkbox"/> |
| 6 S from R?  | 6.....  | <input type="checkbox"/> |
| 7 R from S?  | 7.....  | <input type="checkbox"/> |
| 8 C from S?  | 8.....  | <input type="checkbox"/> |
| 9 L from Y?  | 9.....  | <input type="checkbox"/> |
| 10 C from L? | 10..... | <input type="checkbox"/> |



# 49 Angles

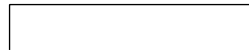

This is a semi-circle:

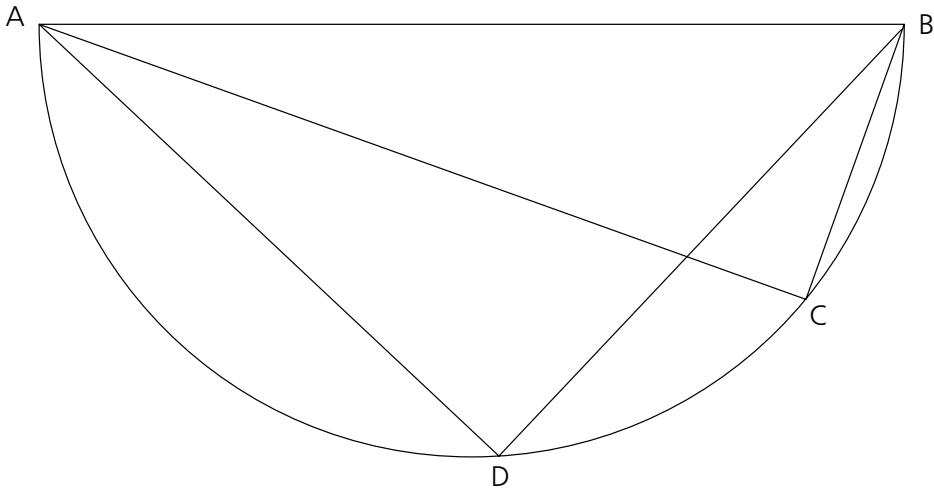

- 1 What is the size of angle ADB?.....1
- 2 Angle ABC =  $70^\circ$ . What is the size of angle BAC? .....2



# 50 Similarity – 1

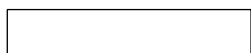

1

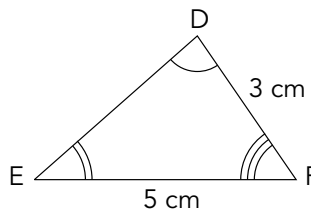
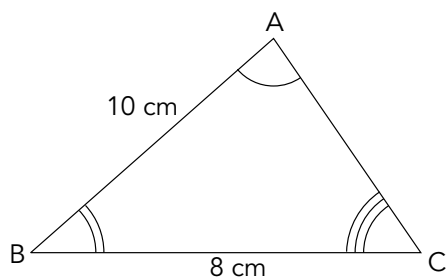

These triangles are similar. Calculate:

- a AC
- b DE

1a.....

b.....

2 Triangle GHI is similar to triangle JKL.

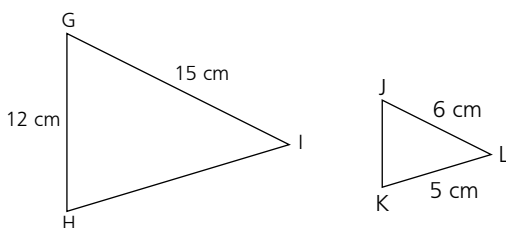

Find:

- a HI
- b JK

2a.....

b.....

3 AC is parallel to DE.

- AC = 10 cm
- DE = 8 cm
- AB = 12 cm
- EB = 9 cm

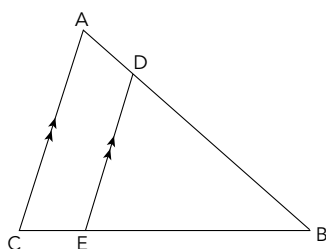

Find:

- a BD
- b BC

3a.....

b.....



# 51 Similarity – 2

1

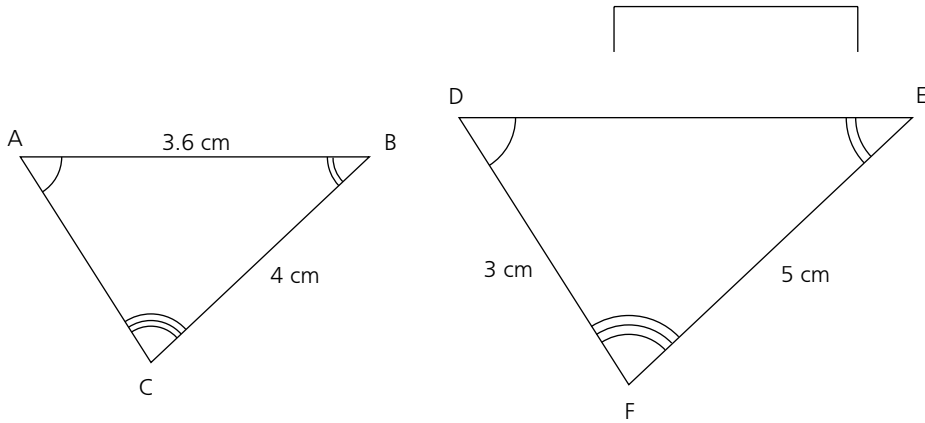

Triangle ABC is similar to triangle DEF. Calculate:

- a AC 1a.....
- b DE b.....

2 These triangles are similar. Equal angles are marked.

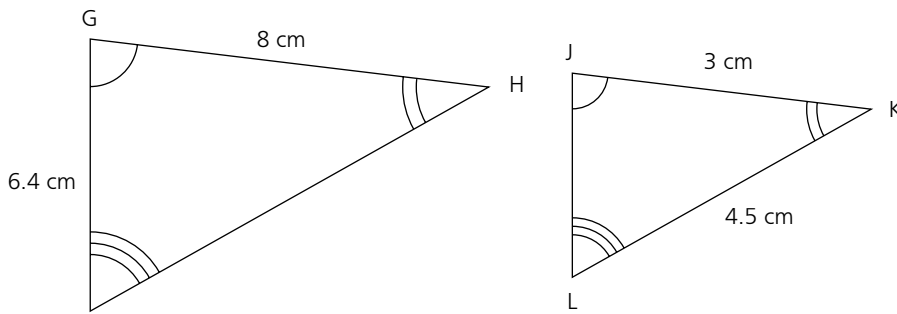

Calculate:

- a HI 2a.....
- b JL b.....

3 These triangles are similar. Equal angles are marked.

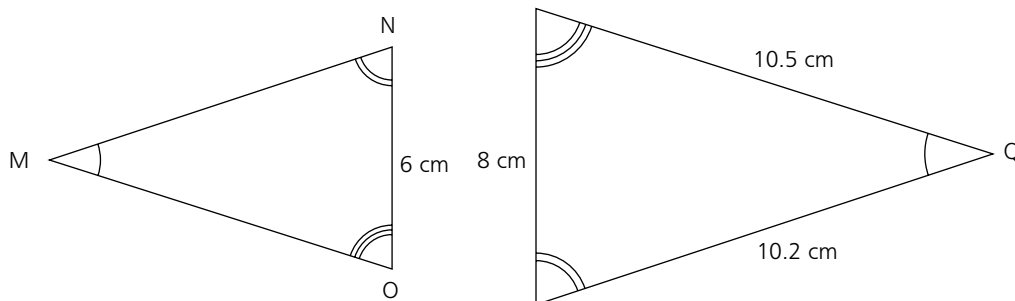

Calculate:

- a MN 3a.....
- b MO b.....

# 52 Congruent triangles – 1

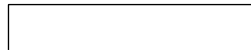

Decide which of the following triangles are congruent.

If they are congruent give a reason, eg SAS.

If they are not congruent write 'not' in the answer column.

1

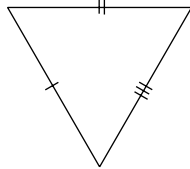
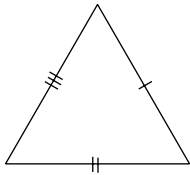

1.....

2

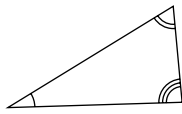
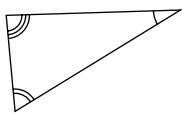

2.....

3

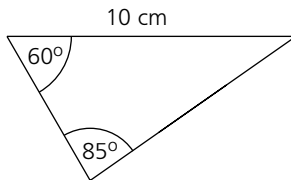
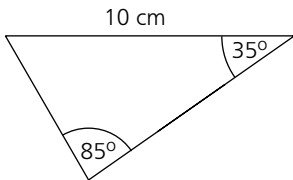

3.....

4

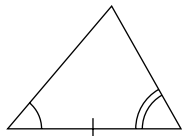
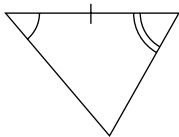

4.....

5

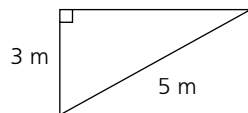
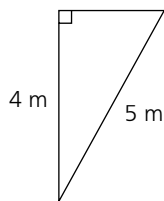

5.....

6

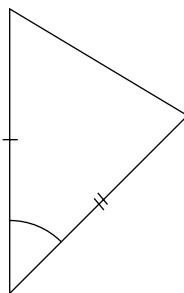
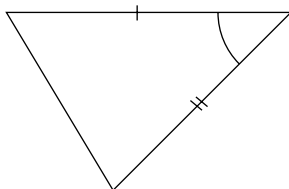

6.....

7

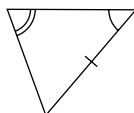
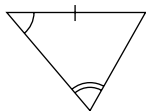

7.....

8

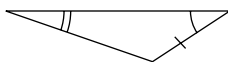
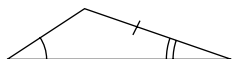

8.....

## 53 Congruent triangles – 2

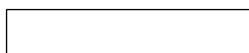

These two triangles are congruent:

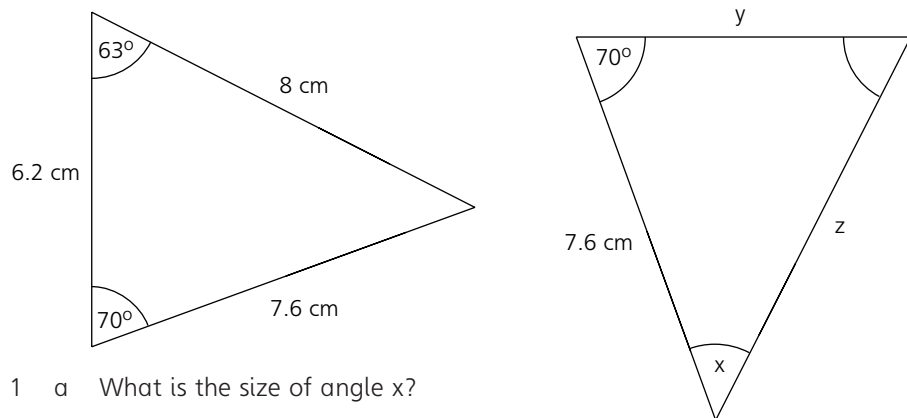

- 1 a What is the size of angle x?
- b What is the length of side y?
- c What is the length of side z?

- 1a.....
- b.....
- c.....

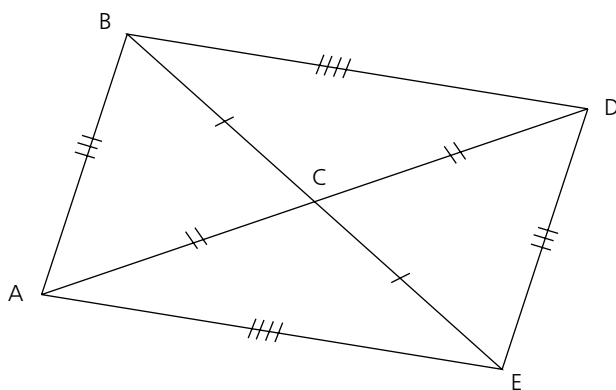

- 2 a Which triangle is congruent to triangle ABC?
- b Which triangle is congruent to triangle ACE?
- c Which angle is equal to angle CAE?
- d Which angle is equal to angle CAB?
- e Which angle is equal to angle DCE?

- 2a.....
- b.....
- c.....
- d.....
- e.....



## 54 Combined and inverse transformations

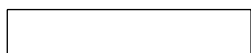

1 A shape Y is translated by the vector  $\begin{pmatrix} -2 \\ 4 \end{pmatrix}$  to produce Y'.  
 Describe the transformation to return Y' to Y.      1.....  
 .....  
 .....

2 A shape Z is reflected in the line  $y = 2x + 1$  to produce Z'.  
 Describe the transformation to return Z' to Z.      2.....  
 .....  
 .....

3 A shape W is rotated through an angle of  $60^\circ$  clockwise, centre of rotation the point (5, 2), to produce W'.  
 a Describe the inverse transformation to return W' to W. 3a.....  
 .....  
 .....

b Describe a clockwise rotation to return W' to W.      b.....  
 .....  
 .....

4 A shape V is enlarged by a scale factor of -3, centre of enlargement the point (5, 1), to produce V'.  
 Describe the transformation to return V' to V.      4.....  
 .....  
 .....

5 A shape T is enlarged by a scale factor of  $\frac{2}{5}$ , centre of enlargement the point (-2, 6), to produce T'.  
 Describe the transformation to return T' to T.      5.....  
 .....  
 .....

6 A shape R is reflected in the line  $y = 0$  to produce R'.  
 R' is then reflected in the line  $x = 0$  to produce R''.  
 Describe a single transformation to take R to R''.      6.....  
 .....  
 .....

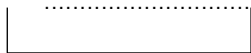

# 55 Enlargement by a fractional scale factor

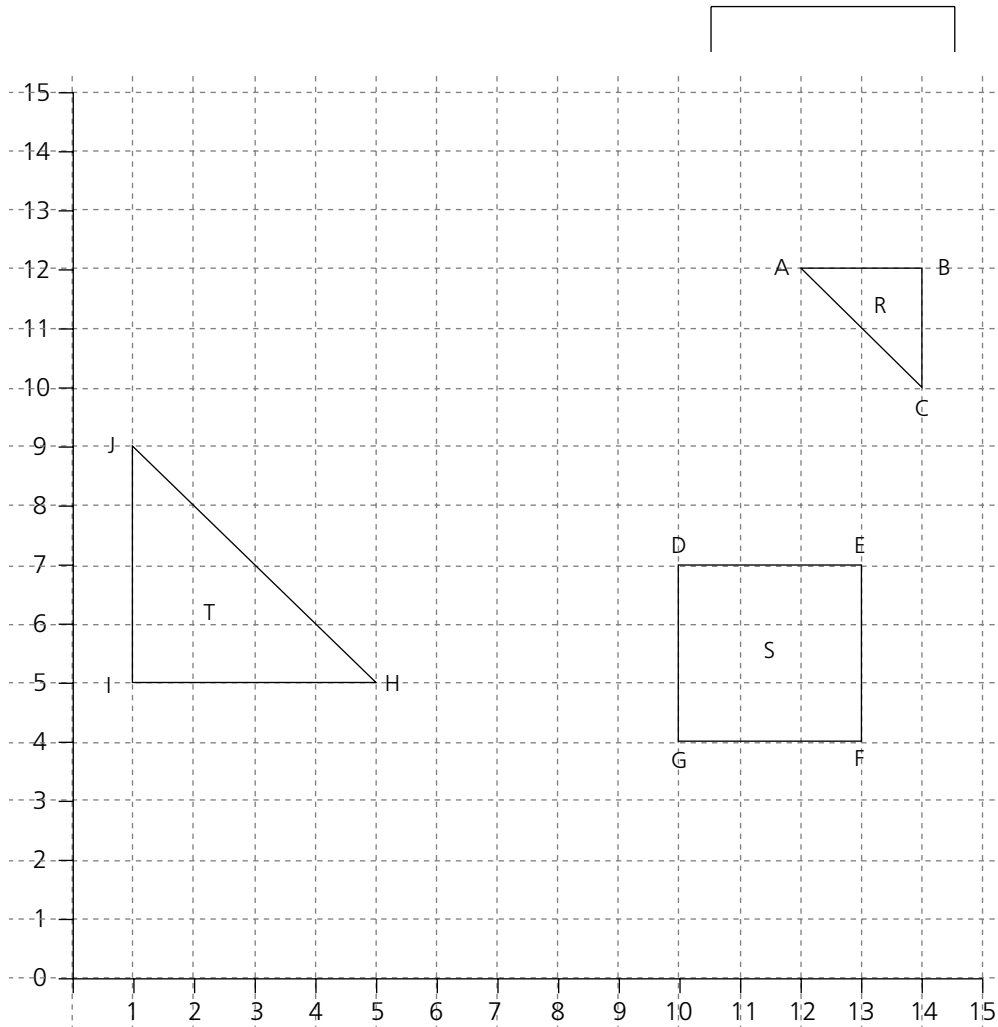

- 1 Enlarge the triangle R by a scale factor of  $\frac{1}{2}$ .  
Centre of enlargement is the point (8, 14).
- 2 Enlarge the square S by a scale factor of  $\frac{1}{3}$ .  
Centre of enlargement is the point (1, 13).
- 3 Enlarge the square S by a scale factor of  $\frac{2}{3}$ .  
Centre of enlargement is the point (1, 13).
- 4 Enlarge the triangle T by a scale factor of  $\frac{1}{4}$ .  
Centre of enlargement is the point (13, 1).

- 1 A' = .....
- B' = .....
- C' = .....
- 2 D' = .....
- E' = .....
- F' = .....
- G' = .....
- 3 D'' = .....
- E'' = .....
- F'' = .....
- G'' = .....
- 4 H' = .....
- I' = .....
- J' = .....



# 56 Enlargement by a negative scale factor

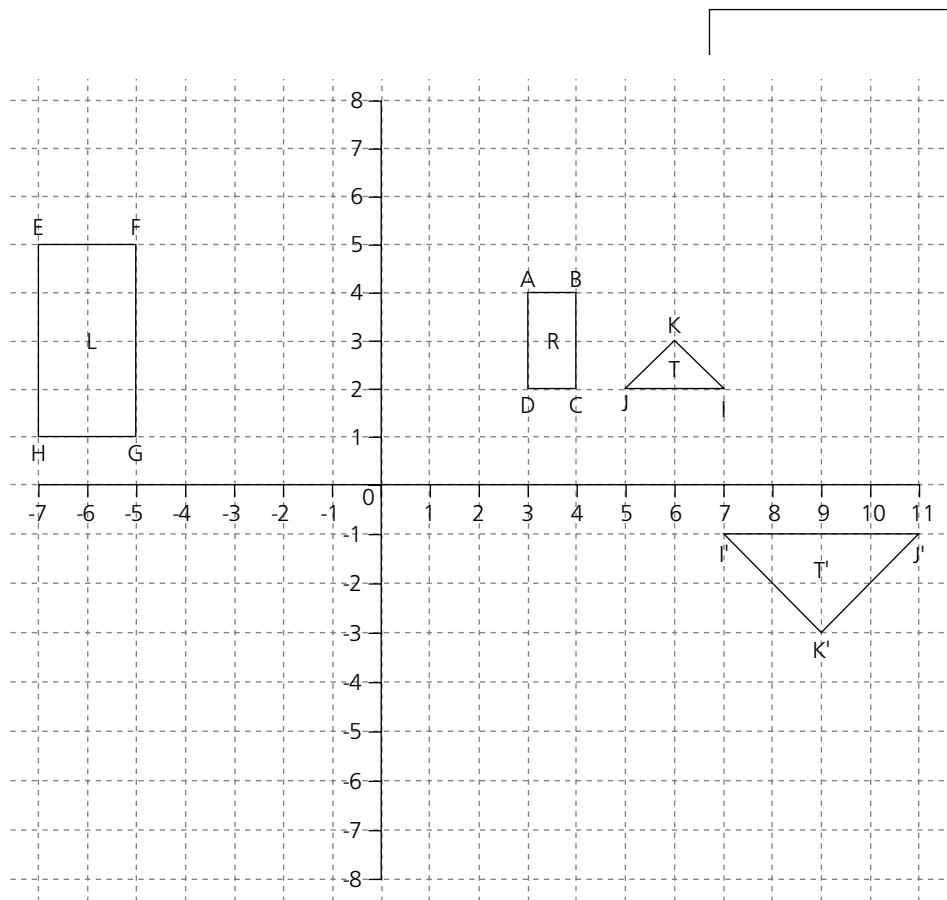

1 Enlarge rectangle R by a scale factor of -3, centre of enlargement the point (2, 1), to form R'. Mark A'B'C'D' on the rectangle R'. Write the new co-ordinates in the answer column.

- 1 A'.....
- B'.....
- C'.....
- D'.....

2 Enlarge rectangle L by a scale factor of -1/2, centre of enlargement the point (-1, -1), to form L'. Mark E'F'G'H' on the rectangle L'. Write the new co-ordinates in the answer column.

- 2 E'.....
- F'.....
- G'.....
- H'.....

3 T is an enlargement of T'.  
 a What are the co-ordinates of the centre of enlargement?  
 b What is the scale factor of the enlargement?

- 3a.....
- b.....

# 57 Translations

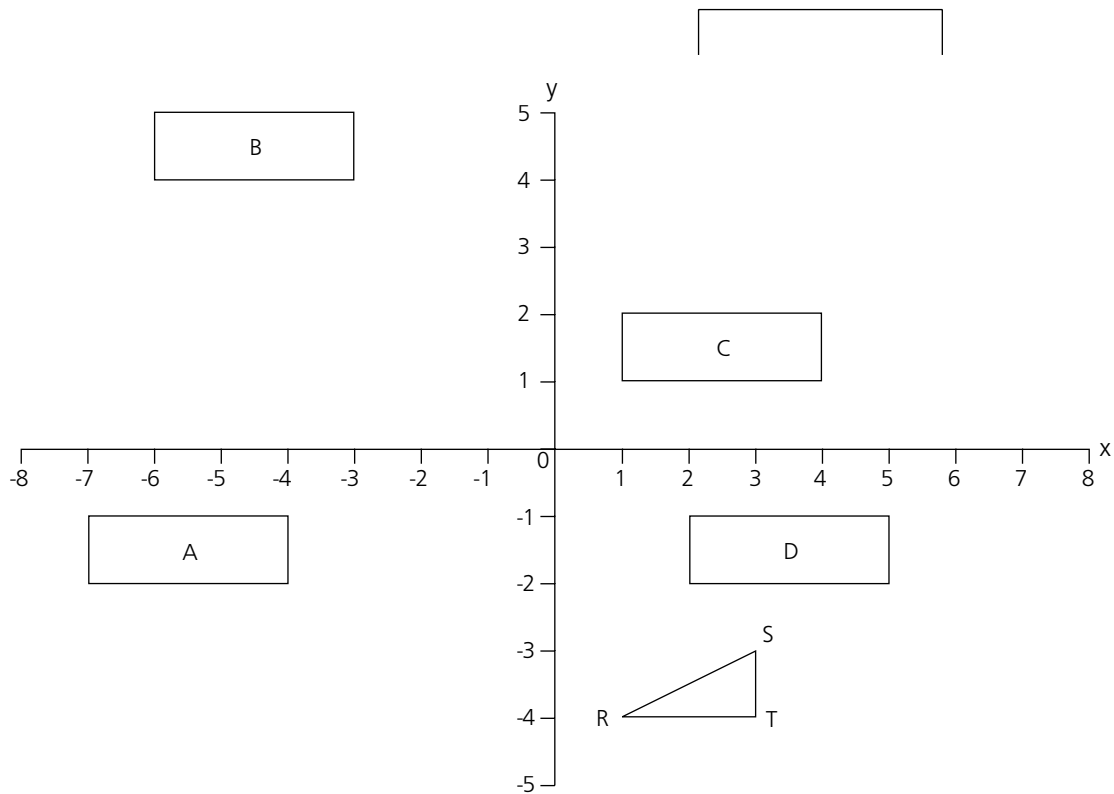

Describe the translation that moves:

- 1 A to B 1 .....
- 2 A to C 2 .....
- 3 D to A 3 .....
- 4 D to C 4 .....
- 5 B to D 5 .....

Translate the triangle RST using the following instructions.

Draw the shape and give the new co-ordinates of R.

- 6 4 units right, 6 units up. 6 .....
- 7 4 units left, 1 unit down. 7 .....
- 8 7 units left, 5 units up. 8 .....
- 9 3 units right, 1 unit down. 9 .....



## 58 Compound measures

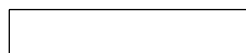

- 1 A car travels 283 kilometres in 3 hours 17 minutes.  
Calculate the average speed, correct to three significant figures. 1.....
- 2 A ship travels 471 kilometres in 12 hours 47 minutes.  
Calculate the average speed correct to three significant figures. 2.....
- 3 A train travels at an average speed of 87 kilometres per hour  
for 6 hours 14 minutes. Calculate the distance travelled. 3.....
- 4 A plane travels at 378 kilometres per hour for 48 minutes.  
Calculate the distance travelled. 4.....
- 5 A liquid has a volume of  $58.3 \text{ cm}^3$  and a mass of 71.3 grams.  
Calculate the density, correct to three significant figures. 5.....
- 6 The density of a block of wood, volume  $78.5 \text{ cm}^3$ , is  $0.87 \text{ g/cm}^3$ .  
Calculate the mass. 6.....
- 7 A train travels at a speed of 17.8 metres per second.  
Calculate the speed in kilometres per hour. 7.....



# 59 Time

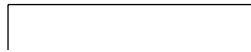

1 A train travelled from London to Exeter. The journey took 4 hours 37 minutes. The train left London at 13.51.  
What time did it arrive in Exeter? 1.....

2 A car left York at 07.37. It arrived in Carlisle at 10.08.  
How long did the journey take? 2.....

3 A train travelled from Manchester to London. The journey took 3 hours 38 minutes. The train arrived in London at 17.13.  
What time did the train leave Manchester? 3.....

4 A car travelled 328 kilometres at an average speed of 39 kilometres per hour. Calculate the time taken:  
a to the nearest minute 4a.....

b to the nearest second. b.....  
.....

5 A train travelled 34 kilometres at an average speed of 63 kilometres per hour. Calculate the time taken:  
a to the nearest minute 5a.....

b to the nearest second. b.....  
.....

6 A plane travelled at 378 kilometres per hour. It travelled a distance of 827 kilometres. Calculate the time taken:  
a to the nearest minute 6a.....

b to the nearest second. b.....  
.....



## 60 Upper and lower bounds – 1

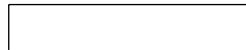

In each question give:

a the maximum value

b the minimum value.

- |                                                                                       |          |                          |
|---------------------------------------------------------------------------------------|----------|--------------------------|
| 1 A book, mass 1.3 kilograms                                                          | 1a.....  | <input type="checkbox"/> |
|                                                                                       | b.....   | <input type="checkbox"/> |
| 2 A bottle of vinegar, capacity 28 centilitres                                        | 2a.....  | <input type="checkbox"/> |
|                                                                                       | b.....   | <input type="checkbox"/> |
| 3 A bag of crisps, mass 25 grams                                                      | 3a.....  | <input type="checkbox"/> |
|                                                                                       | b.....   | <input type="checkbox"/> |
| 4 A cupboard, 1.72 metres high                                                        | 4a.....  | <input type="checkbox"/> |
|                                                                                       | b.....   | <input type="checkbox"/> |
| 5 A car, mass 1.283 tonnes                                                            | 5a.....  | <input type="checkbox"/> |
|                                                                                       | b.....   | <input type="checkbox"/> |
| 6 A pencil, length 15.3 centimetres                                                   | 6a.....  | <input type="checkbox"/> |
|                                                                                       | b.....   | <input type="checkbox"/> |
| 7 A fly, length 13.28 millimetres                                                     | 7a.....  | <input type="checkbox"/> |
|                                                                                       | b.....   | <input type="checkbox"/> |
| 8 A tank, capacity 74.3 litres                                                        | 8a.....  | <input type="checkbox"/> |
|                                                                                       | b.....   | <input type="checkbox"/> |
| 9 A book, length 16.00 centimetres                                                    | 9a.....  | <input type="checkbox"/> |
|                                                                                       | b.....   | <input type="checkbox"/> |
| 10 A box, mass 30.0 kilograms                                                         | 10a..... | <input type="checkbox"/> |
|                                                                                       | b.....   | <input type="checkbox"/> |
| 11 A parcel weighing 780 grams accurate to the nearest 20 grams.                      | 11a..... | <input type="checkbox"/> |
|                                                                                       | b.....   | <input type="checkbox"/> |
| 12 A can of drink containing 330 millilitres correct to the nearest five millilitres. | 12a..... | <input type="checkbox"/> |
|                                                                                       | b.....   | <input type="checkbox"/> |



## 61 Upper and lower bounds – 2

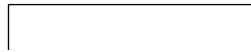

1 A glass holds 280 ml, correct to two significant figures.

a What is the maximum capacity of the glass? 1a.....

b What is the minimum capacity of the glass? b.....

A tank holds 70 litres of lemonade, correct to one significant figure.

c What is the maximum number of glasses that can be filled from the tank? c.....

d What is the minimum number of glasses that can be filled from the tank? d .....

2 A = 6.42

B = 0.68

C = 0.35

D = 4.20

A, B, C and D are each correct to two decimal places. Calculate the upper and lower bound of the following sums. Give the answers correct to five significant figures where appropriate.

a  $AB + D$  2a Upper .....   
Lower .....

b  $3AC - 8B$  b Upper .....   
Lower .....

c  $\frac{3A}{5D}$  c Upper .....   
Lower .....

d  $\frac{4A}{3B} - (2C - 3B)$  d Upper .....   
Lower .....



## 62 Length, area and volume of shapes with curves

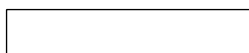

O is the centre of each circle.

- 1 a Find the length of the arc x.  
b Find the area of sector OAB.

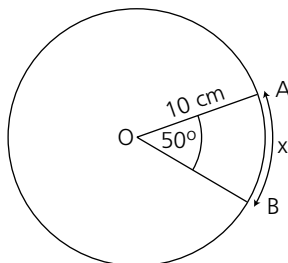

1a.....

b.....

- 2 a Find the shaded area.  
b Find the length of the chord AB.

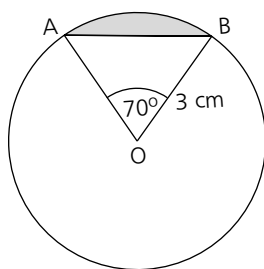

2a.....

b.....

- 3 The radius of this circle is 7 cm.

- a Find the length of arc Y.  
b Find the shaded area.

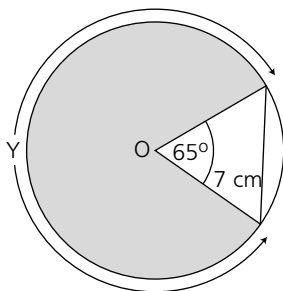

3a.....

b.....

- 4 The radius of a sphere is 6 cm. Find:

- a the total surface area.  
b the volume.

4a.....

b.....

- 5 This cone has a base radius of 3 cm and a height of 4 cm.

- a Find the volume [volume =  $\frac{1}{3}\pi r^2 h$ ].  
b Find the slant height.  
c Find the curved surface area.

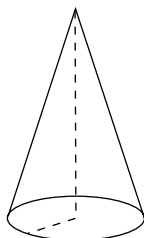

5a.....

b.....

c.....



# 63 Angle and tangent properties of circles – 1

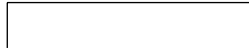

Find the size of the marked angles.

O is the centre of each circle.

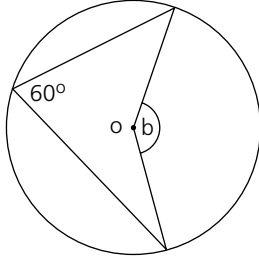
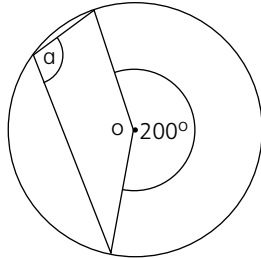

a.....

b.....

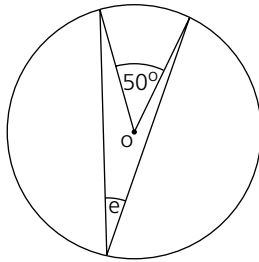
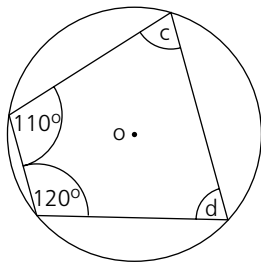

c.....

d.....

e.....

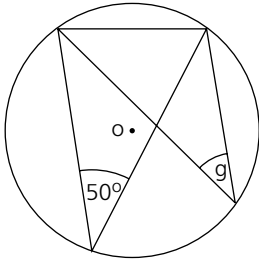
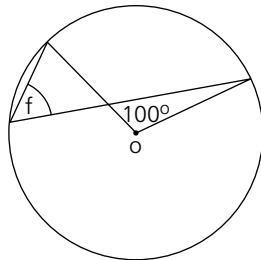

f.....

g.....

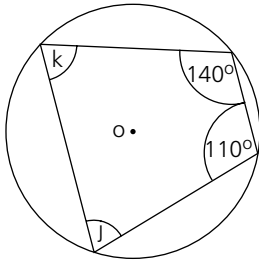
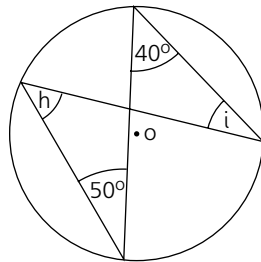

h.....

i.....

j.....

k.....

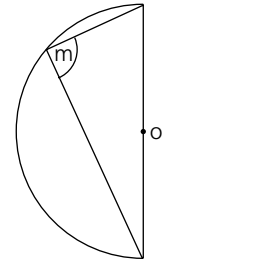
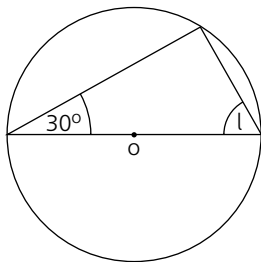

l.....

m.....





## 64 Angle and tangent properties of circles – 2

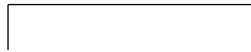

O is the centre of the circle.

1 Angle  $ATC = 50^\circ$

Angle  $DTB = 45^\circ$

Find:

a Angle  $ATB$

b Angle  $TAB$

c Angle  $ABT$

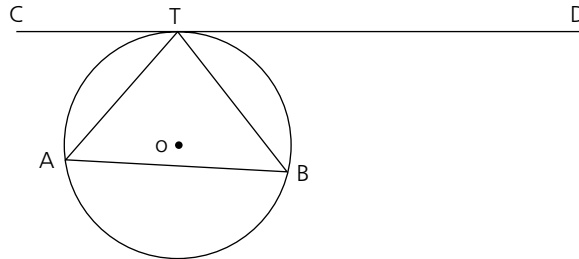

1a.....

b.....

c.....

2 Angle  $ATB = 40^\circ$

Find angle  $AOB$ .

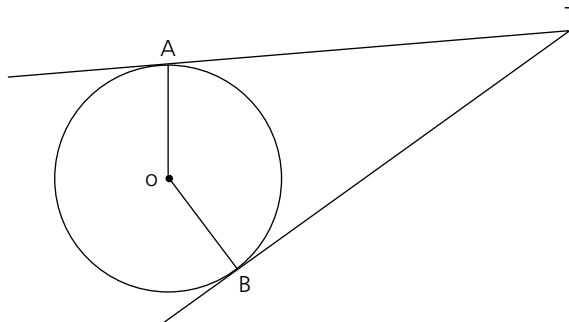

2.....

3 Angle  $BAT = 40^\circ$

Find:

a Angle  $ABT$

b Angle  $ATC$

c Angle  $BTD$

d Angle  $ATB$

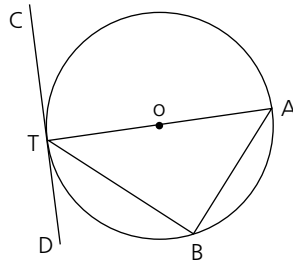

3a.....

b.....

c.....

d.....

4 Which triangle is congruent to  $TOA$ ?

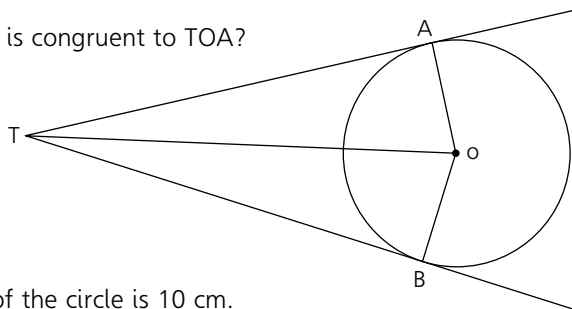

4.....

5 The diameter of the circle is 10 cm.

$OT = 15$  cm

Calculate the length  $AT$ .

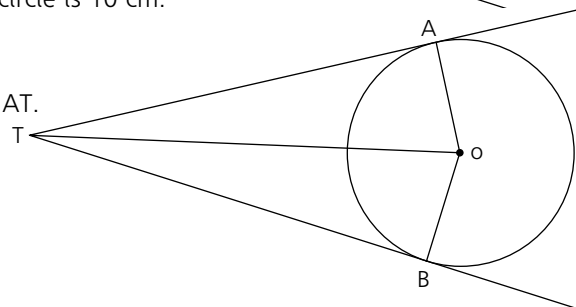

5.....



# 65 Angle and tangent properties of circles – 3

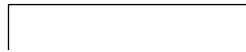

Find the marked angles. O is the centre of each circle.

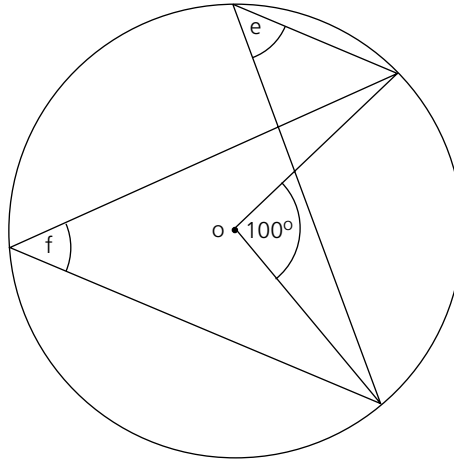
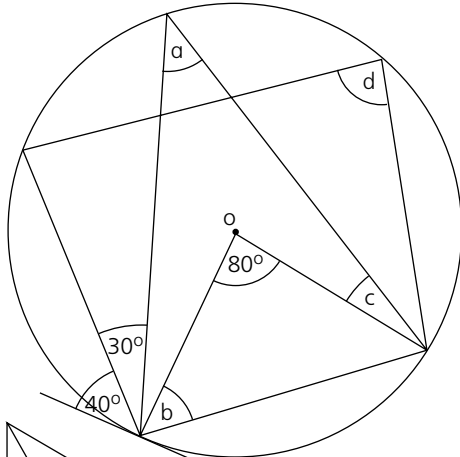

- a.....
- b.....
- c.....
- d.....
- e.....
- f.....

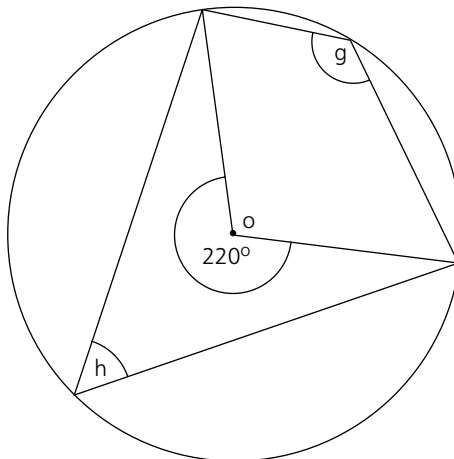
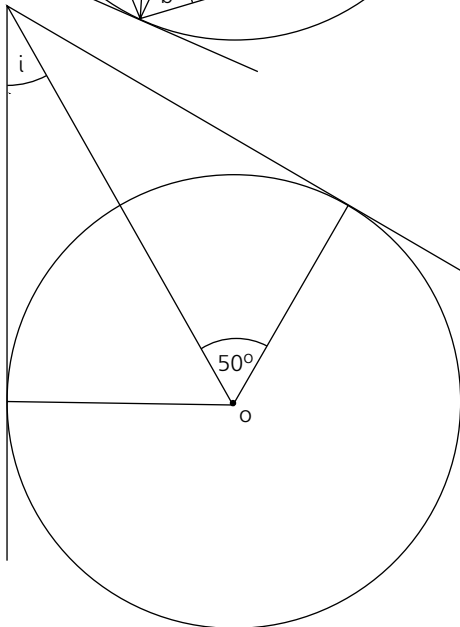

- g.....
- h.....
- i.....

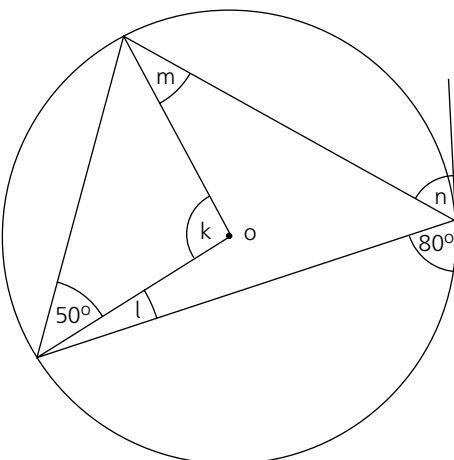
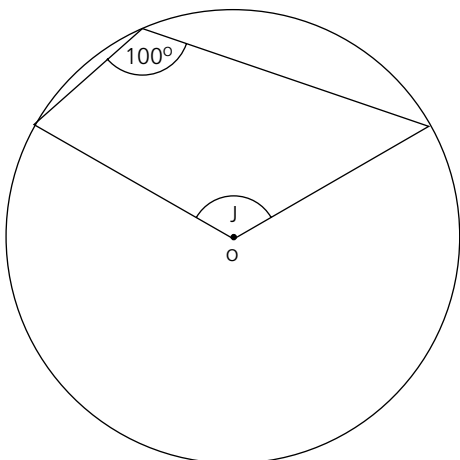

- j.....
- k.....
- l.....
- m.....
- n.....



# 66 Calculating length, area and volume – 1

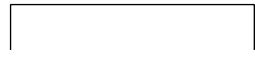

1 Find: a the area; b the perimeter of a square, side 6 cm.

1a.....

b.....

2 Find: a the area; b the perimeter of this triangle.

2a.....

b.....

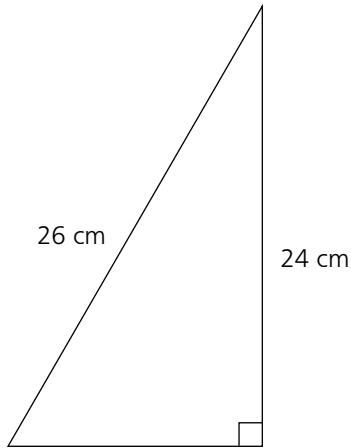

3 Find the area of this triangle.

3.....

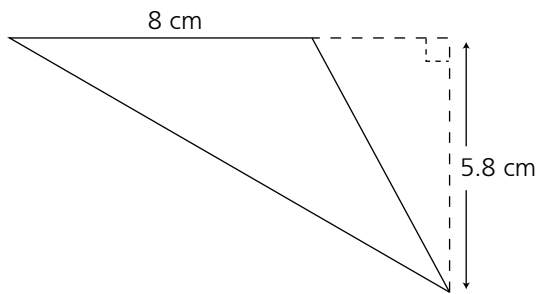

4 Find the volume of this cuboid.

4.....

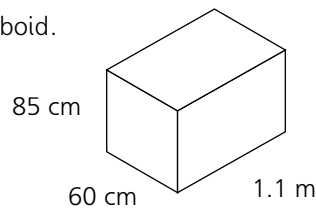

5 The area of this triangle is  $50 \text{ cm}^2$ . Find  $x$ .

5.....

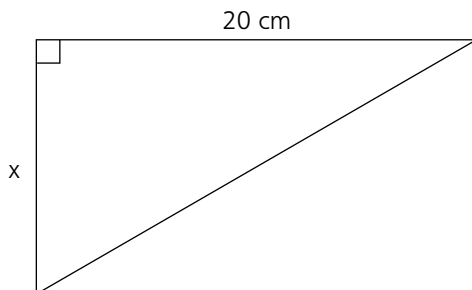

6 The volume of a cuboid is  $100 \text{ cm}^3$ , the length is 8 cm and the width is 5 cm. Find the height.

.....

# 67 Calculating length, area and volume – 2

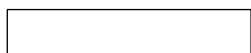

Find the volume of these prisms:

1

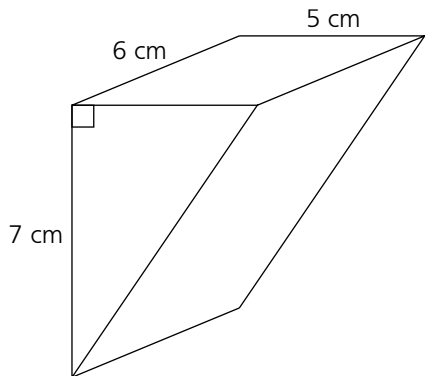

1 .....

2

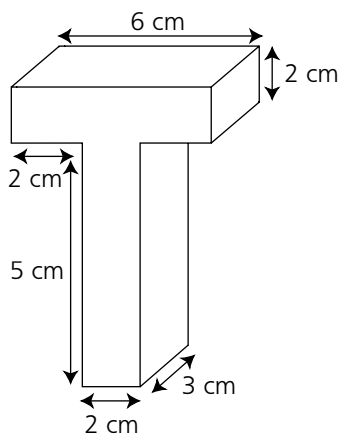

2 .....

3

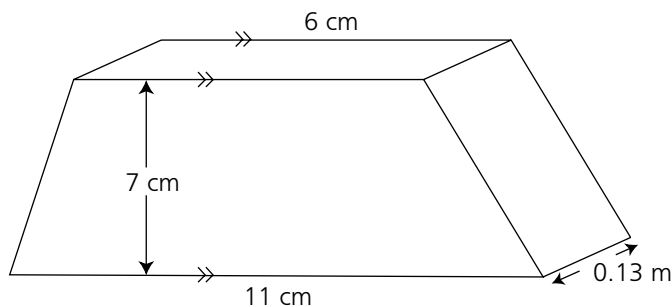

3 .....

4

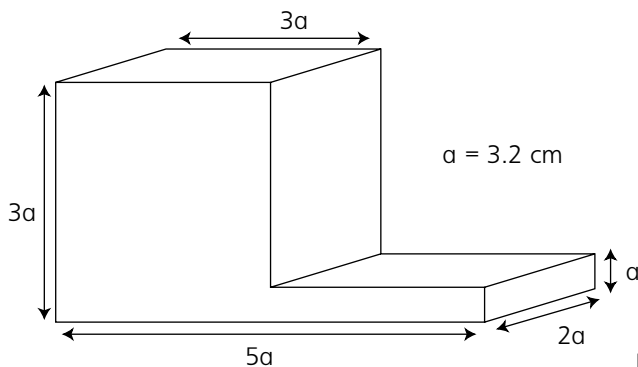

4 .....



# 68 Calculating length, area and volume – 3

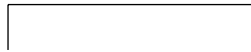

Find:

a the perimeter

b the area of these shapes.

1a.....

b.....

1

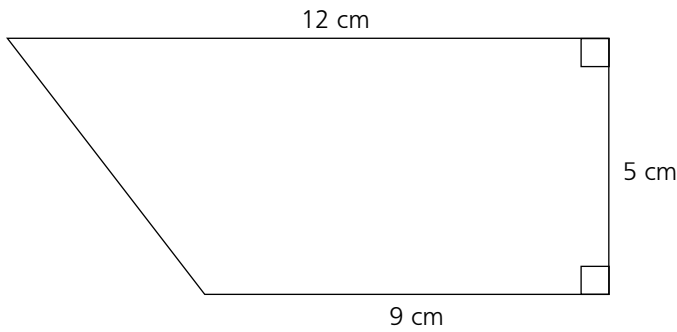

2

2a.....

b.....

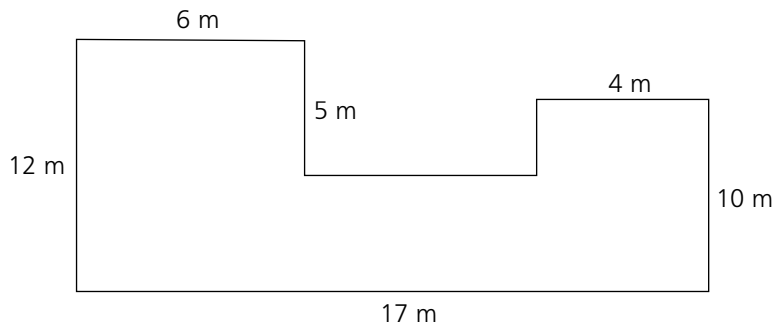

3 This is a diagram of a swimming pool with a concrete path all the way around. The pool is 18 m long and 15 m wide. The path is 2.5 m wide.

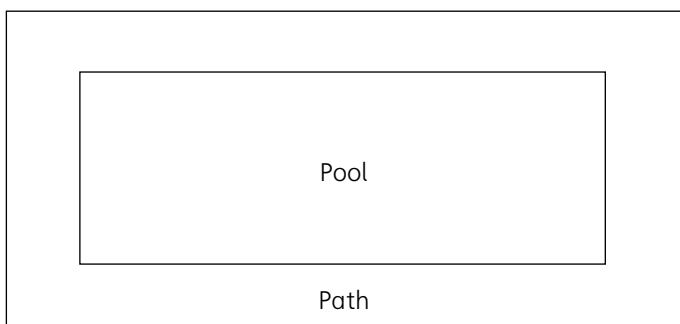

a Find the area of the path.

3a.....

b The path is made of concrete. The concrete is 8 mm deep. Find the volume of concrete. Give your answer in m<sup>3</sup>.

b.....



## 69 Formulae for length, area and volume

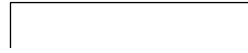

$a$ ,  $b$ ,  $c$  and  $d$  are lengths,  $r$  is the radius.

State whether each formula gives a length, area, volume or none of these.

1  $2a + 5a$  1.....

2  $3c + 2c^2$  2.....

3  $abc + 3de$  3.....

4  $\frac{6abc}{2d}$  4.....

5  $3\pi r^2 + abc$  5.....

6  $6\pi r + a - 3c$  6.....

7  $5ab + \pi r^2$  7.....

8  $\frac{a^3c^2}{bc^2}$  8.....

9  $\frac{6abc^2}{3d}$  9.....

10  $\frac{2}{3}ac \times 3d$  10.....

11  $\frac{ab}{c} + \frac{d^3}{c^2}$  11.....

12  $\frac{a^3b}{d}$  12.....



## 70 Ratio for length, area and volume

1 Cube A has a side of 4 cm, cube B has a side of 7 cm.

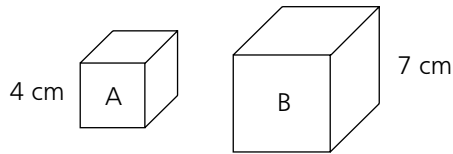

a What is the ratio of the length of a side of cube A to a side of cube B?      1a.....

b What is the ratio of the total surface area of cube A to the total surface area of cube B?      b.....

c What is the ratio of the volume of cube A to the volume of cube B?      c.....

2 Cube C has a side of  $3x$ , cube D has a side of  $8x$ . Express the volume of Cube C to Cube D as a ratio. Give your answer in its lowest terms.      2.....

3 A map is drawn with a scale of 4 cm represents 5 km.  
a A lake has an area of  $200 \text{ km}^2$ . What is the area on the map?      3a.....

b On the map a forest has an area of  $8 \text{ cm}^2$ .  
What is the actual area of the forest?      b.....

4 A model aircraft is constructed using identical materials to the actual aircraft. The scale is 4:100.

a The length of the real plane is 40 m. What is the length of the model plane? (Give your answer in cm.)      4a.....

b The area of a wing on the model plane is  $200 \text{ cm}^2$ . What is the area of the wing on the actual aircraft? (Give your answer in  $\text{m}^2$ .)      b.....

c The actual aircraft weighs 80 tonnes. What is the weight of the model plane? (Give your answer in kg.)      c.....

# 71 Pythagoras' theorem

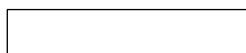

Find the missing side.

Give your answer correct to three significant figures.

1

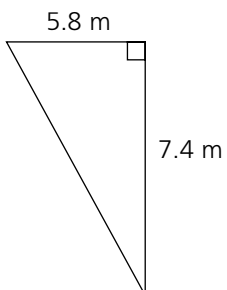

1.....

2

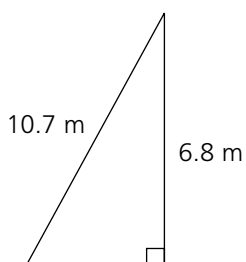

2.....

3

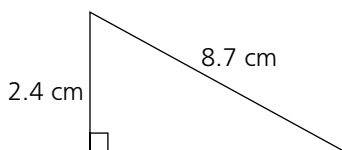

3.....

4 Calculate the area of this triangle.

4.....

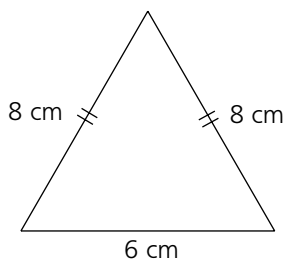

5 The area of this triangle is 20 cm<sup>2</sup>. Find x.

5.....

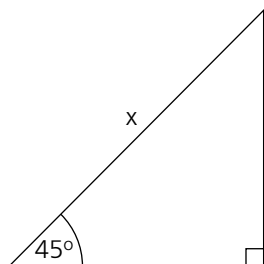



## 72 Trigonometry: Finding an angle – 1

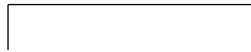

Calculate the size of the angles indicated.

Give your answer correct to three significant figures.

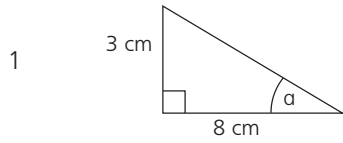

1a = .....

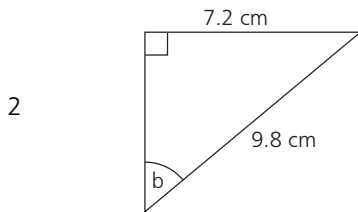

2b = .....

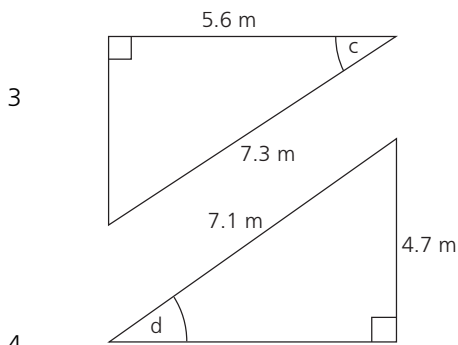

3c = .....

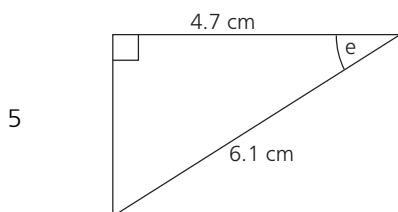

4d = .....

5e = .....

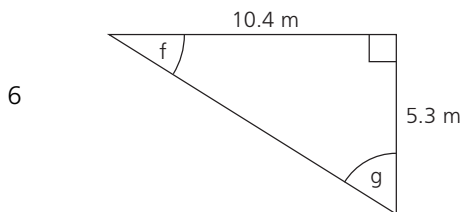

6f = .....

g = .....

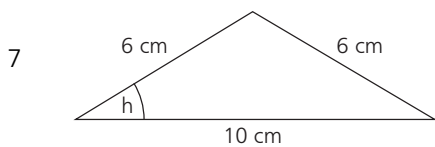

7h = .....

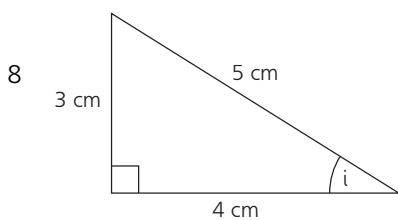

8i = .....



## 73 Trigonometry: Finding an angle – 2

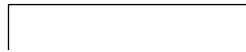

Calculate the size of the indicated angles.

Give your answer correct to three significant figures.

1

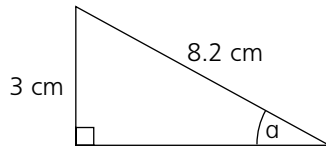

1a = .....

2

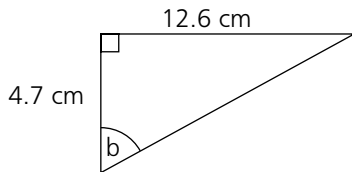

2b = .....

3

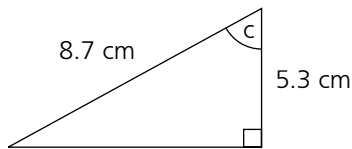

3c = .....

4

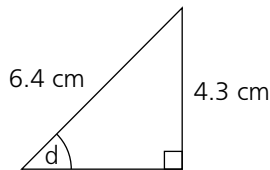

4d = .....

5

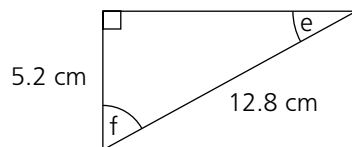

5e = .....

f = .....

6

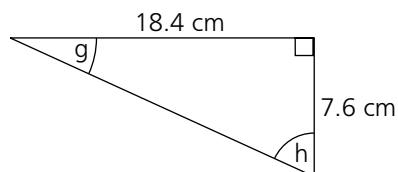

6g = .....

h = .....

7

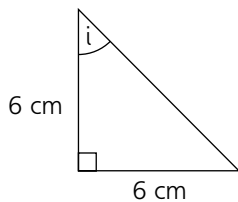

7i = .....

8

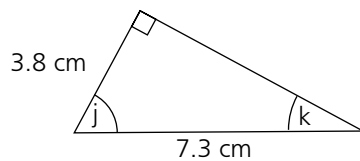

8j = .....

k = .....



# 74 Trigonometry: Finding a side – 1

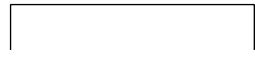

Calculate the size of the sides indicated.

Give your answer correct to three significant figures.

1

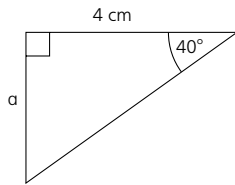

1a = .....

2

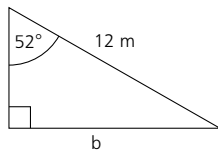

2b = .....

3

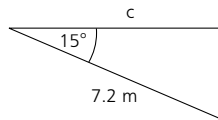

3c = .....

4

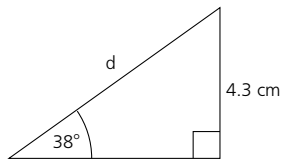

4d = .....

5

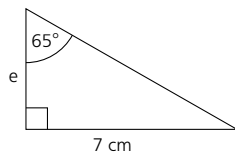

5e = .....

6

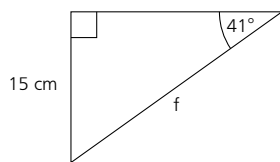

6f = .....

7

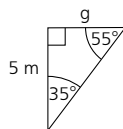

7g = .....

8

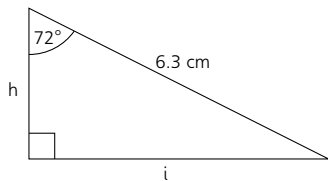

8h = .....

i = .....



## 75 Trigonometry: Finding a side – 2

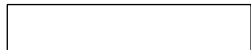

Calculate the size of the indicated sides.

Give your answer correct to three significant figures.

1  1a = .....

2  2b = .....

3  3c = .....

4  4d = .....

5  5e = .....

6  6f = .....

7  7g = .....   
h = .....

8  8i = .....



# 76 Trigonometry: Solving problems – 1



1 A plane is detected by radar at a distance of 8000 m and at an angle of elevation of 25°.

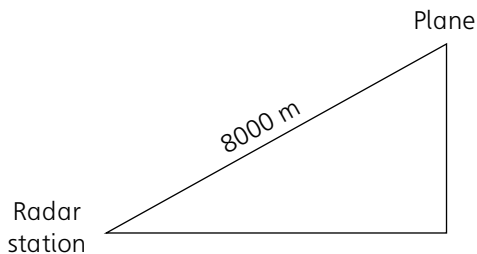

a What is the angle of depression of the radar station from the plane? 1a.....

Assume the ground is level. Calculate:

b the height of the plane above the ground b.....

c the distance, along the ground, from the spot directly under the plane to the radar station. c.....

2 The angle of depression from the top of this building T to a point P on the ground which is 20 m away from the building is 41°.

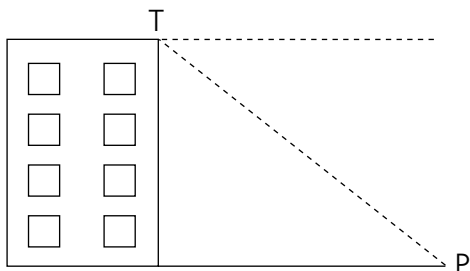

a Calculate the height of the building. 2a.....

b Calculate the distance from P to T. b.....

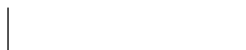

# 77 Trigonometry: Solving problems – 2

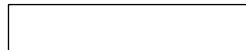

1 A rocket is fired at an angle of elevation of  $62^\circ$ .  
It travels at a speed of 200 metres per second.

a How long will it take to reach a height of 20 000 metres?  
Give your answer to the nearest second.

1a.....

b How far will the rocket have travelled?  
Give your answer to the nearest metre.

b.....

2 A bird is sitting on top of a telegraph post.  
The post is 12 metres high. The bird sees a worm in the ground.  
The angle of depression from the bird to the worm is  $50^\circ$ .

a Calculate the distance of the worm from the bottom of the telegraph post.

2a.....

b How far is the bird from the worm?

b.....



# 78 Trigonometry and Pythagoras' theorem in 3-D shapes

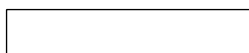

- 1 This diagram shows a horizontal rectangular field.  
At one corner there is a vertical radio mast.

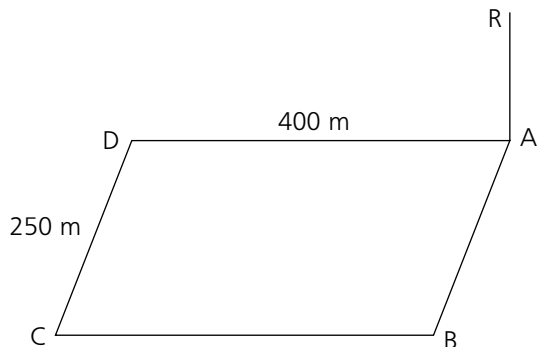

- a The angle of elevation of the top of the radio mast R from B is  $10^\circ$ .  
Find the height of the radio mast.

1a.....

- b What is the angle of depression from the top of the radio mast R to the point C?

b.....

- c What is the distance from R to C?

c.....

- 2 This is a cube, side 5 cm.

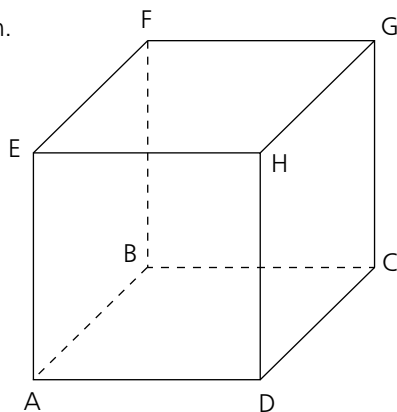

- a What is the distance from B to D?

2a.....

- b What is the distance from B to H?

b.....

- c What is the size of angle CEG?

c.....



# 79 Sine, cosine and tangent of any angle – 1

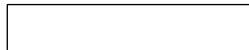

1 Complete this table and hence draw  $y = \cos x$ .  
(Give values of  $y$  correct to two decimal places.)

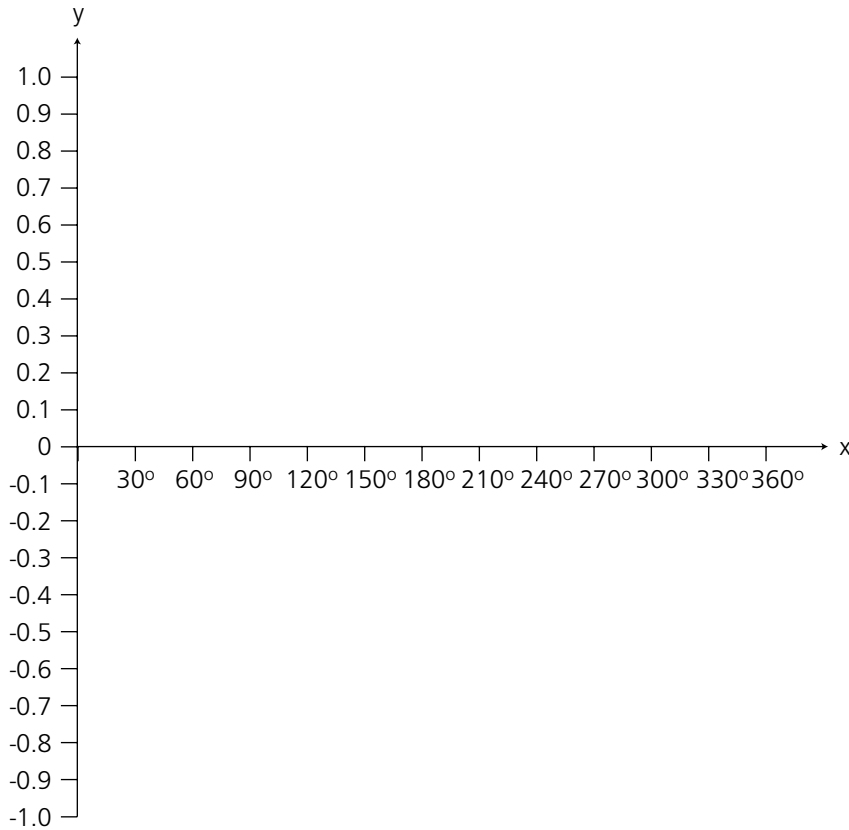

x	y
0°	
30°	
60°	
90°	
120°	
150°	
180°	
210°	
240°	
270°	
300°	
330°	
360°	

Table

Graph

Draw appropriate lines on your graph to find values of  $x$  which satisfy the following equations. If no value exists write 'none'. Write down values of  $x$  between:

- a 0° and 90° which satisfies the equation  $\cos x = 0.7$  a .....
- b 90° and 180° which satisfies the equation  $\cos x = 0.7$  b .....
- c 180° and 270° which satisfies the equation  $\cos x = 0.7$  c .....
- d 270° and 360° which satisfies the equation  $\cos x = 0.7$  d .....
- e 360° and 540° which satisfies the equation  $\cos x = 0.7$  e .....
- f 540° and 720° which satisfies the equation  $\cos x = 0.7$  f .....
- g 0° and 90° which satisfies the equation  $\cos x = -0.7$  g .....
- h 90° and 180° which satisfies the equation  $\cos x = -0.7$  h .....
- i 180° and 270° which satisfies the equation  $\cos x = -0.7$  i .....
- j 270° and 360° which satisfies the equation  $\cos x = -0.7$  j .....
- k 360° and 540° which satisfies the equation  $\cos x = -0.7$  k .....
- l 540° and 720° which satisfies the equation  $\cos x = -0.7$  l .....





# 80 Sine, cosine and tangent of any angle – 2

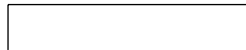

1  $\sin x^\circ = 0.9659$

- a Give all the possible values of  $x$  between  $0^\circ$  and  $360^\circ$ .  
Give the value of  $x$  correct to three significant figures.

1a.....   
 .....

$\sin y^\circ = -0.9659$

- b Give all of the possible values of  $y$  between  $0^\circ$  and  $360^\circ$ .  
Give the value of  $y$  correct to three significant figures.

b.....   
 .....

2  $\sin 40^\circ = 0.642787609$

- a Find another angle between  $0^\circ$  and  $360^\circ$  where  $\sin x^\circ = 0.642787609$ .

2a.....

- b Find two angles between  $360^\circ$  and  $720^\circ$  where  $\sin x^\circ = 0.642787609$ .

b.....   
 .....

3  $\tan 200^\circ = 0.363970234$

- a Find another angle between  $0^\circ$  and  $360^\circ$  where  $\tan x = 0.363970234$ .

3a.....

- b Find two angles between  $0^\circ$  and  $360^\circ$  where  $\tan x = -0.363970234$ .

b.....   
 .....

4  $\cos x^\circ = -0.891$

- a Find all of the possible values of  $x$  between  $0^\circ$  and  $360^\circ$ .  
Give the value of  $x$  correct to three significant figures.

4a.....   
 .....

- b Find the smallest value of  $x$ , which is greater than  $360^\circ$ ,  
where  $\cos x^\circ = 0.891$ . Give the value of  $x$  correct to three significant figures.

b.....



# 81 Sine, cosine and tangents of any angle – 3

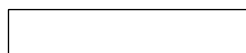

1 Complete this table of values and hence draw the graph of  $y = 2\sin x + 1$  for  $0 \leq x \leq 360$  using  $30^\circ$  intervals.

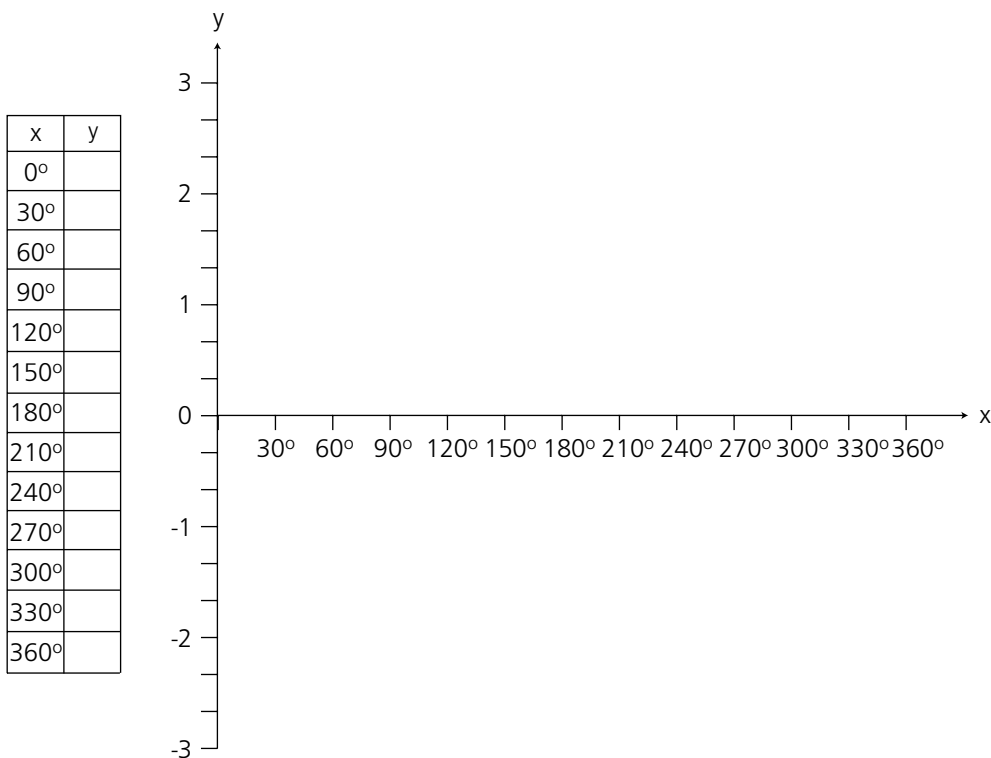

Table

Graph

Use your graph to find values of  $x$  between  $0^\circ$  and  $360^\circ$  for which:

a  $2\sin x + 1 = 0$

a .....

.....

b  $2\sin x + 1 = -0.5$

b .....

.....

c  $2\sin x + 1 = 1.5$

c .....

.....



## 82 Sine rule, cosine rule, area of a triangle – 1

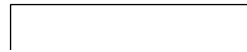

1 Find y:

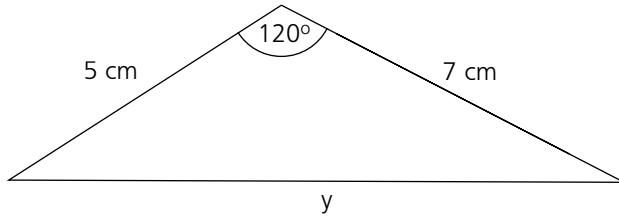

**Sine rule**

$$\frac{a}{\sin A} = \frac{b}{\sin B}$$

**Cosine rule**

To find an angle

$$\cos A = \frac{b^2 + c^2 - a^2}{2bc}$$

To find a side

$$a^2 = b^2 + c^2 - 2bc \cdot \cos A$$

1.....

2 Find y:

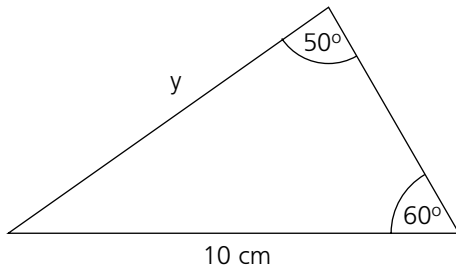

2.....

3 Find y:

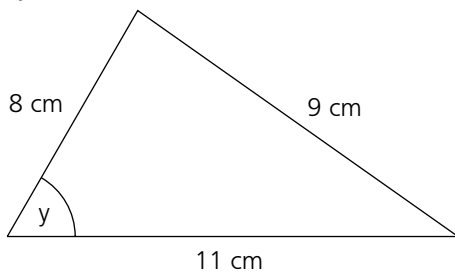

3.....

4 Find y:

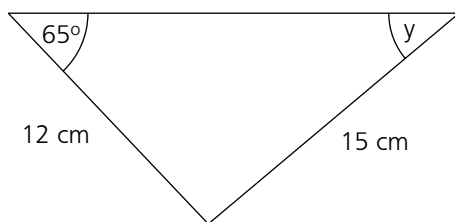

4.....

5 Find the area of this triangle.

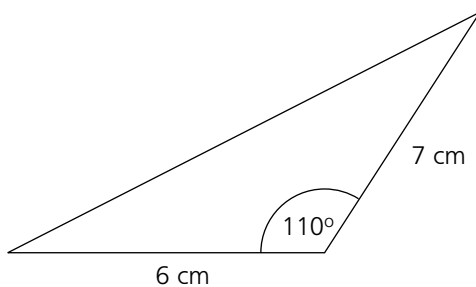

5.....



### 83 Sine rule, cosine rule, area of a triangle – 2

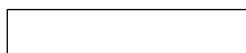

1 Two ships leave port at 13.00.

Ship A travels on a bearing of  $075^\circ$  at a speed of 12 kilometres per hour.

Ship B travels on a bearing of  $110^\circ$  at a speed of 30 kilometres per hour.

a How far apart are the ships at 15.30? 1a.....

b What is the bearing of ship A from ship B? b.....

2 A triangle has a perimeter of 384 m.

The length of the sides are in the ratio 7:8:9.

a Calculate the size of the largest angle. 2a.....

b Calculate the area of the triangle. b.....



# 84 Vectors – 1

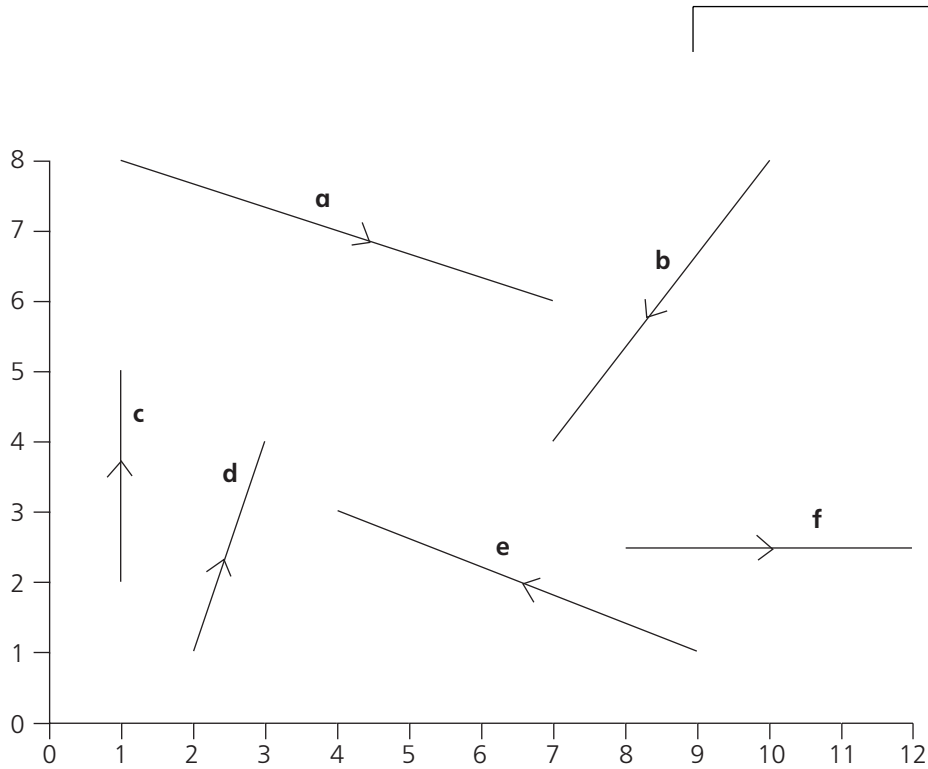

Write the following vectors in the form  $\begin{pmatrix} x \\ y \end{pmatrix}$ .

- |                     |         |                          |
|---------------------|---------|--------------------------|
| 1 <b>a</b>          | 1.....  | <input type="checkbox"/> |
| 2 <b>b</b>          | 2.....  | <input type="checkbox"/> |
| 3 <b>c</b>          | 3.....  | <input type="checkbox"/> |
| 4 <b>d</b>          | 4.....  | <input type="checkbox"/> |
| 5 <b>e</b>          | 5.....  | <input type="checkbox"/> |
| 6 <b>f</b>          | 6.....  | <input type="checkbox"/> |
| 7 <b>3a</b>         | 7.....  | <input type="checkbox"/> |
| 8 <b>-2e</b>        | 8.....  | <input type="checkbox"/> |
| 9 <b>-d</b>         | 9.....  | <input type="checkbox"/> |
| 10 <b>a + b</b>     | 10..... | <input type="checkbox"/> |
| 11 <b>3a – 2b</b>   | 11..... | <input type="checkbox"/> |
| 12 <b>e + f</b>     | 12..... | <input type="checkbox"/> |
| 13 <b>e – f</b>     | 13..... | <input type="checkbox"/> |
| 14 <b>a + b + c</b> | 14..... | <input type="checkbox"/> |
| 15 <b>2a – 3e</b>   | 15..... | <input type="checkbox"/> |

## 85 Vectors – 2

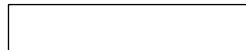

1 DE is parallel to BC.

Vector  $\vec{AC} = \mathbf{x}$

Vector  $\vec{AB} = \mathbf{y}$

$AE = \frac{1}{2} \vec{AC}$

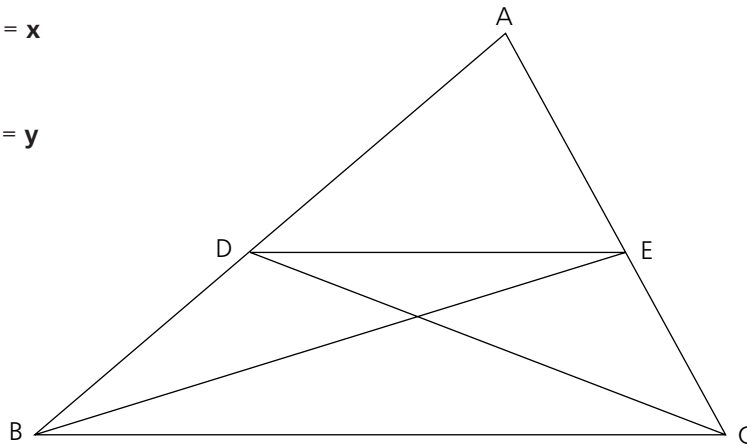

Express these vectors in terms of  $\mathbf{x}$  and  $\mathbf{y}$ .

- |   |            |  |                                  |
|---|------------|--|----------------------------------|
| a | $\vec{AE}$ |  | 1a..... <input type="checkbox"/> |
| b | $\vec{BC}$ |  | b..... <input type="checkbox"/>  |
| c | $\vec{AD}$ |  | c..... <input type="checkbox"/>  |
| d | $\vec{ED}$ |  | d..... <input type="checkbox"/>  |
| e | $\vec{BE}$ |  | e..... <input type="checkbox"/>  |
| f | $\vec{DC}$ |  | f..... <input type="checkbox"/>  |

2 What is the value of x and y?

- |   |                                                                                                                         |                                       |
|---|-------------------------------------------------------------------------------------------------------------------------|---------------------------------------|
| a | $\begin{pmatrix} 3 \\ 5 \end{pmatrix} + \begin{pmatrix} x \\ 6 \end{pmatrix} = \begin{pmatrix} 7 \\ y \end{pmatrix}$    | 2a x = ..... <input type="checkbox"/> |
|   |                                                                                                                         | y = ..... <input type="checkbox"/>    |
| b | $\begin{pmatrix} 2 \\ 8 \end{pmatrix} + \begin{pmatrix} x \\ y \end{pmatrix} = \begin{pmatrix} -3 \\ 10 \end{pmatrix}$  | b x = ..... <input type="checkbox"/>  |
|   |                                                                                                                         | y = ..... <input type="checkbox"/>    |
| c | $\begin{pmatrix} 8 \\ -1 \end{pmatrix} - \begin{pmatrix} x \\ y \end{pmatrix} = \begin{pmatrix} 11 \\ -3 \end{pmatrix}$ | c x = ..... <input type="checkbox"/>  |
|   |                                                                                                                         | y = ..... <input type="checkbox"/>    |



## 86 Vectors – 3

- 1 A ship can sail at 20 km/h in still water. The ship heads due south.  
The current is flowing at 8 km/h due west.



- a What is the actual speed of the ship? 1a .....
- b What is the direction the ship actually takes? (Give the bearing.) b .....

- 2 A ship needs to sail due east from A to B.  
The current is flowing at 2 m/s due north.  
The ship sails at 8 m/s.  
The distance from A to B is 5 km.

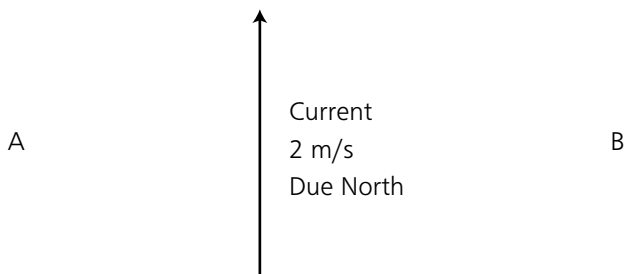

- a In which direction must the ship head? 2a .....
- b How far does the ship actually sail in one second? b .....
- c How long will the journey take?  
Give your answer in minutes and seconds. c .....

# 87 Vectors – 4

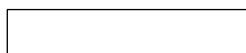

1 Two forces are pulling an object.

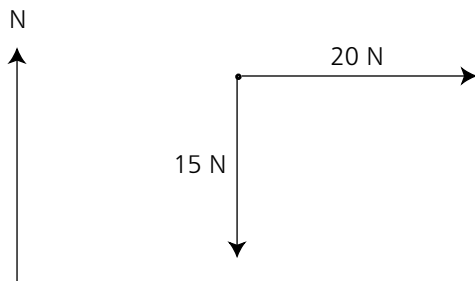

a Calculate the resultant force.

1a.....

b Calculate the direction of that force.

b.....

2 A plane flies from Calder airport to Deacon airport.

The plane flies at 500 km/h in still air.

The wind is blowing at 60 km/h in the direction shown.

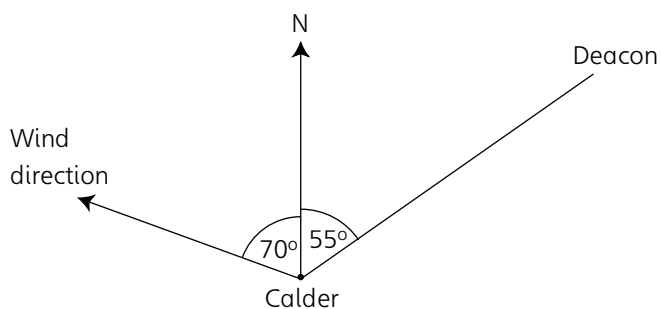

a Find the direction in which the plane must fly.

2a.....

b Find the actual speed of the plane.

b.....





# 88 Locus

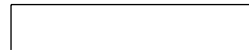

- 1 Construct the locus of the point which is always 2 cm from the line AB.

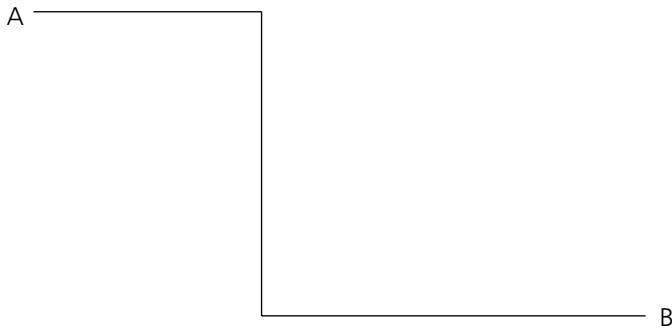

1

- 2 Bisect the angle ABC. Show all construction lines.

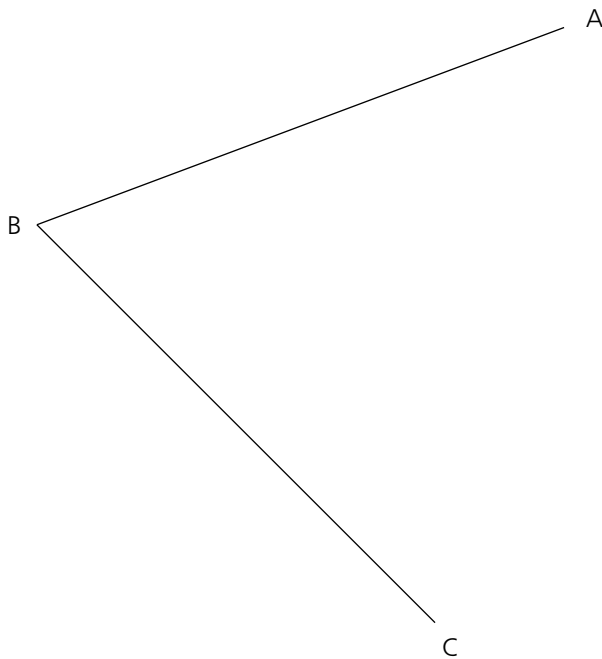

2

---

2

# 89 Designing questionnaires

Criticise these questions for finding out the ages of people.

1 What is your age?

.....  
.....  
.....

1

2 What is your age? Tick one box.

- under 30
- over 30

.....  
.....  
.....

2

3 What is your age? Tick one box.

- 0-20
- 20-40
- 40-60
- 60-80
- 80-100

.....  
.....  
.....  
.....

3

4 What is your age? Tick one box.

- young
- middle aged
- old

.....  
.....  
.....  
.....  
.....

4

4

# 90 Sampling

- 1 A golf club has 500 members. It is decided a survey should be carried out to find out what food to serve at lunch time. A survey of 100 members is taken. Use stratified random sampling to decide how many members of each age should be taken.

Age	Number of members
Under 20	80
20 to under 40	150
40 to under 60	195
60 and over	75

Sample size

.....

.....

.....

.....

- 2 In a university there are 800 students. A survey of 60 students is taken.
- 222 students study maths
- 278 students study English
- 119 students study science
- 181 students study languages

Use stratified random sampling to determine how many students should be selected for the survey from:

a maths	2a.....	<input type="checkbox"/>
b English	b.....	<input type="checkbox"/>
c science	c.....	<input type="checkbox"/>
d languages	d .....	<input type="checkbox"/>
Now total your answers.	Total.....	<input type="checkbox"/>

- 3 In the following surveys a researcher chooses 100 people at random from the electoral roll. State whether this method of sampling is good or bad. If it is bad, say why.

a The researcher wants to know what brand of crisps people buy.	Good or bad
.....	
.....	3a..... <input type="checkbox"/>
b The researcher wants to know how people will vote in a local election.	
.....	
.....	b..... <input type="checkbox"/>

# 91 Hypotheses

How could you test these hypotheses?

Choose from experiment, observation or questionnaire.

- 1 Football is the most popular school sport. 1 .....
  
- 2 Girls can write faster than boys. 2 .....
  
- 3 Most pupils cycle to school. 3 .....
  
- 4 Boys spend more money on clothes than books. 4 .....
  
- 5 Boys can stand on one leg longer than girls. 5 .....
  
- 6 Boys can throw darts better than girls. 6 .....
  
- 7 The school bus arrives late most mornings. 7 .....
  
- 8 Boys aged 15 are taller than girls of the same age. 8 .....
  
- 9 Most children own a computer. 9 .....
  
- 10 Most boys aged 14 like Coca Cola. 10 .....

## 92 Comparing data

1 This table shows the time taken, in seconds, for 20 boys and 20 girls to thread a needle.

Seconds	Boys	Girls
0 – under 5	1	6
5 – under 10	5	8
10 – under 15	7	5
15 – under 20	5	1
20 – under 25	2	0

a Present the data in this frequency polygon.  
Use a dotted line for boys, a solid line for girls.

- - - - Boys      ——— Girls

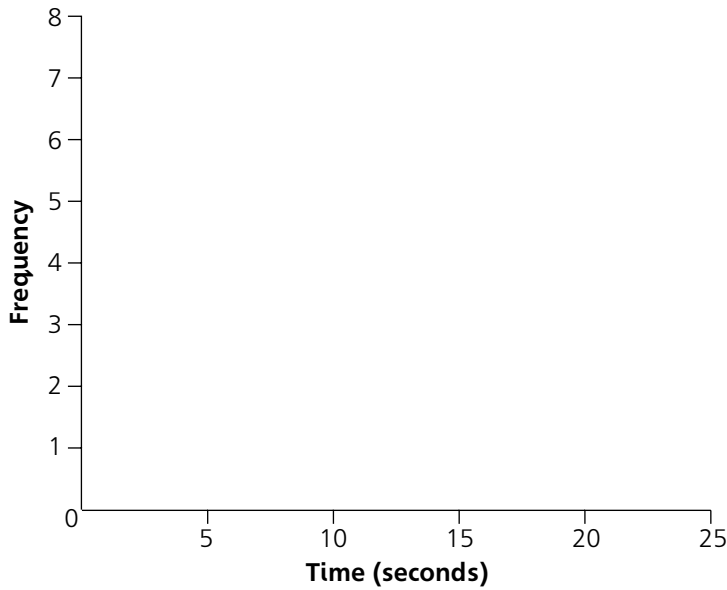

Boys

Girls

b Compare the distributions and comment on your findings.

.....

.....

.....

.....

b

# 93 Histograms

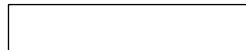

1 This table shows the weights of 50 people in a room.

Fill in the frequency density column and show the information on the graph.

Weight (kg)	Frequency	Frequency density
$20 \leq x < 50$	9	
$50 \leq x < 60$	5	
$60 \leq x < 80$	18	
$80 \leq x < 100$	16	
$100 \leq x < 110$	2	

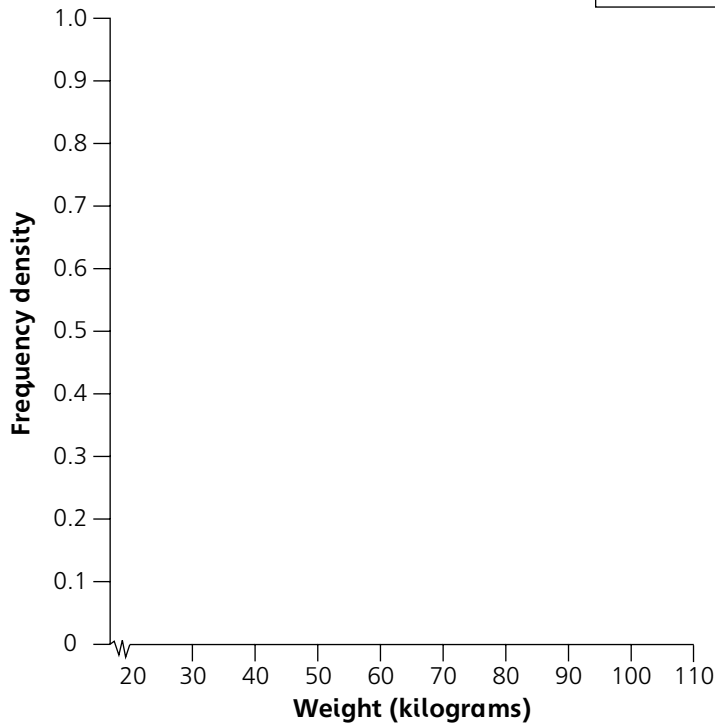

2 This histogram shows the heights in centimetres of dandelions on a lawn.

Use the information in the graph to complete the frequency table.

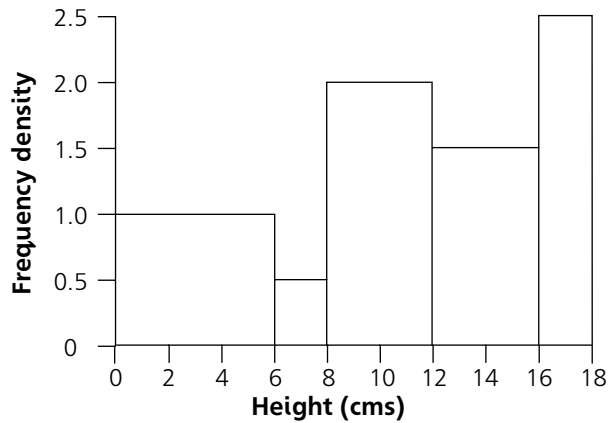

Height (cms)	Frequency
$0 \leq x < 6$	
$6 \leq x < 8$	
$8 \leq x < 12$	
$12 \leq x < 16$	
$16 \leq x < 18$	



## 94 Grouped data

--

- 1 This table shows the mass of people in a cinema.  
Mass is measured in kilograms.

Mass in kilograms	30 – under 40	40 – under 50	50 – under 60	60 – under 70	70 – under 80
Frequency	20	170	140	20	150

- a What is the modal class? 1a.....
- b Estimate the median. b.....
- c Estimate the mean. c.....

- 2 This table shows the prices of 400 bars of chocolate sold in a shop.  
The prices are in pence.

Price in pence	11 – 30	31 – 50	51 – 70	71 – 90	91 – 110
Frequency	96	136	83	62	23

- a What is the modal class? 2a.....
- b Estimate the median. b.....
- c Estimate the mean. c.....

--

# 95 Cumulative frequency – 1

1 This table shows the speed (in kilometres per hour) of cars on a motorway in Britain:

a Complete the cumulative frequency column.

Speed(km/h)	Frequency	Cumulative frequency
70 – under 80	3	
80 – under 90	5	
90 – under 100	12	
100 – under 110	18	
110 – under 120	12	
120 – under 130	10	

- 
- 
- 
- 
- 
- 

b Complete this cumulative frequency diagram.

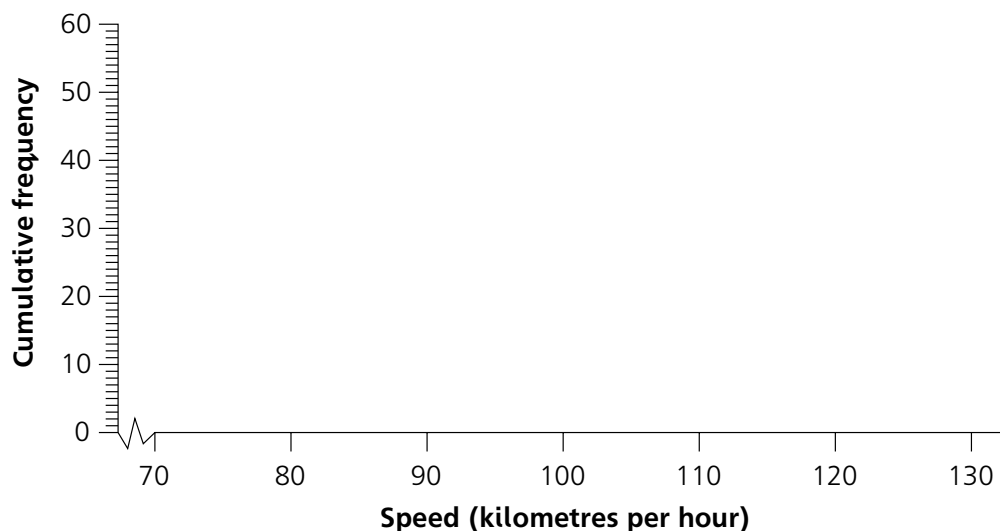

- 
- 

Show your method on the cumulative frequency diagram when answering these questions:

- c What is the median? c.....
- d What is the upper quartile? d.....
- e What is the lower quartile? e.....
- f What is the interquartile range? f.....
- g Cars travelling at more than 112 km/h were breaking the speed limit.  
How many cars were breaking the speed limit? g.....

Save this worksheet. You will need it for Worksheet 97.



## 96 Cumulative frequency – 2

1 This table shows the heights of 100 boys aged 16.  
The height is in centimetres.

a Complete the cumulative frequency values.

Height (centimetres)	Frequency	Cumulative frequency
150 – under 160	12	
160 – under 170	18	
170 – under 180	40	
180 – under 190	28	
190 – under 200	2	

- 
- 
- 
- 
- 

b Complete this cumulative frequency diagram.

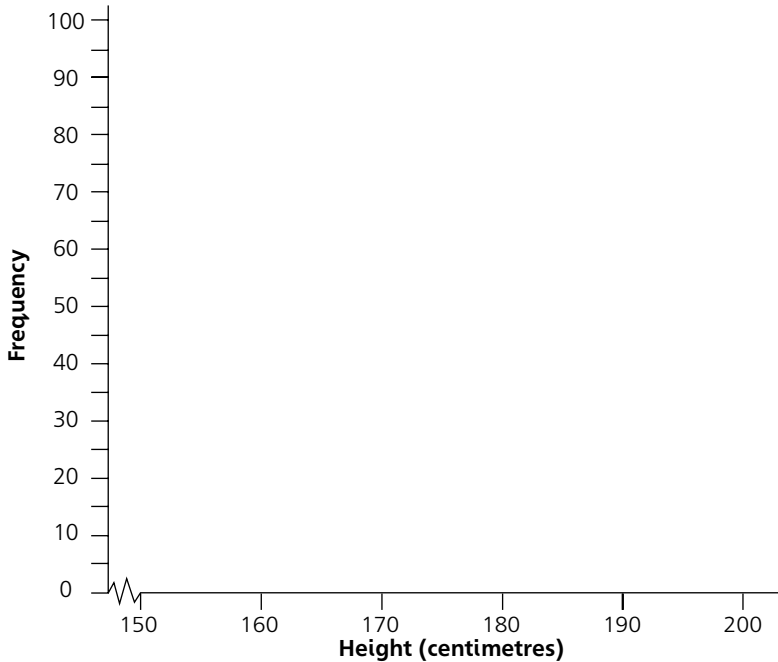

- 

Show your method on the cumulative frequency diagram when answering these questions:

- c What is the median mark? c.....
- d What is the upper quartile? d.....
- e What is the lower quartile? e.....
- f What is the interquartile range? f.....
- g Everyone who is 187 centimetres or over plays basketball. Everyone under 187 centimetres plays football. How many boys play basketball? g.....

Save this worksheet. You will need it for Worksheet 98.

# 97 Using cumulative frequency diagrams to compare data – 1

- 1 This table shows the speed (in kilometres per hour) of cars on a European motorway:
- a Complete the cumulative frequency column.

Speed (km/h)	Frequency	Cumulative frequency
70 – under 80	0	
80 – under 90	0	
90 – under 100	5	
100 – under 110	8	
110 – under 120	21	
120 – under 130	16	

- b Complete the cumulative frequency diagram.

Use the median and interquartile range to compare the speed of cars on the European motorway with the speed of cars on the British motorway in exercise 95.

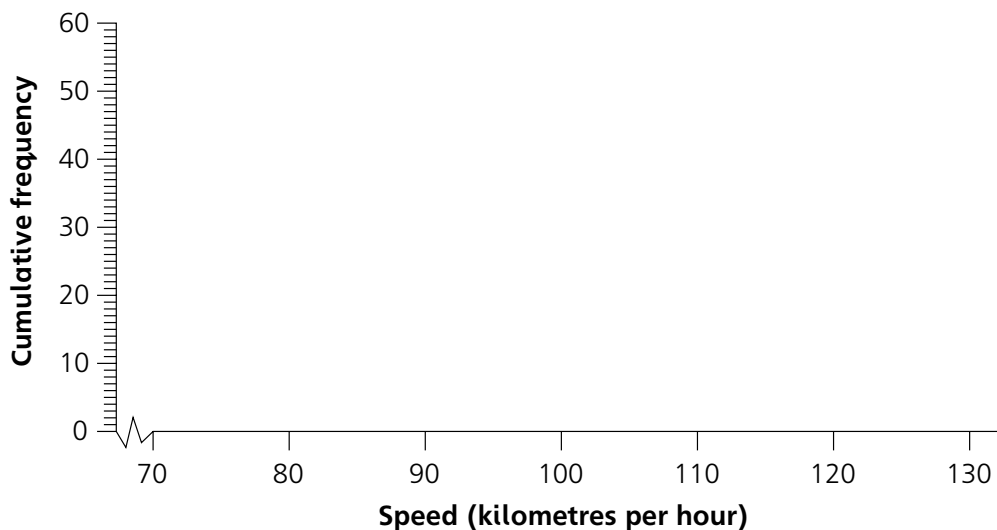
- Comparison
- ..... Median .....
- ..... Upper quartile.....
- ..... Lower quartile.....
- ..... Interquartile range.....
- ..... Comparison

## 98 Using cumulative frequency diagrams to compare data – 2

- 1 This table shows the heights of 100 girls aged 16. The heights are in centimetres.  
 a Complete the cumulative frequency values.

Height (centimetres)	Frequency	Cumulative frequency
140 – under 150	7	
150 – under 160	23	
160 – under 170	24	
170 – under 180	42	
180 – under 190	4	

- 

- b Complete this cumulative frequency graph.

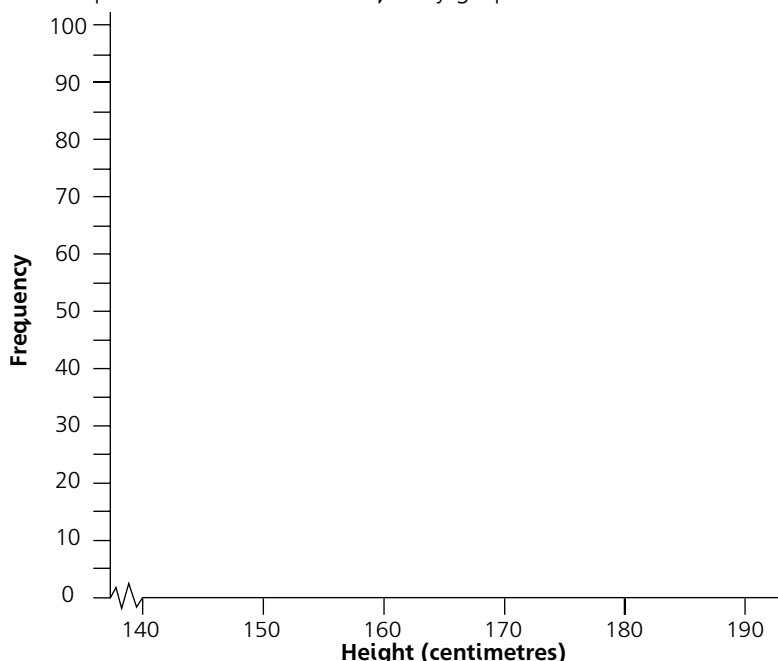

- 

Use the frequency diagram to find the:

- c median c.....   
 d upper quartile d.....   
 e lower quartile e.....   
 f interquartile range. f.....

- g Use the medians and interquartile ranges to compare the heights of girls and boys aged 16. The heights of boys aged 16 can be seen on Worksheet 96.

Comparison

.....  
 .....  
 .....

- g

# 99 Line of best fit

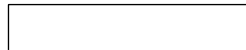

1 This table shows the heights and hand spans of ten boys aged 16.

Boy	Adam	Ben	Colin	Dean	Ewan	Frank	Geoff	Harry	Ian	Joe
Height (cm)	190	192	182	180	178	184	175	191	195	186
Hand span (cm)	21	22	19	18	16	18	15	21	23	20

- a Complete this scatter diagram.
- b Draw a line of best fit.

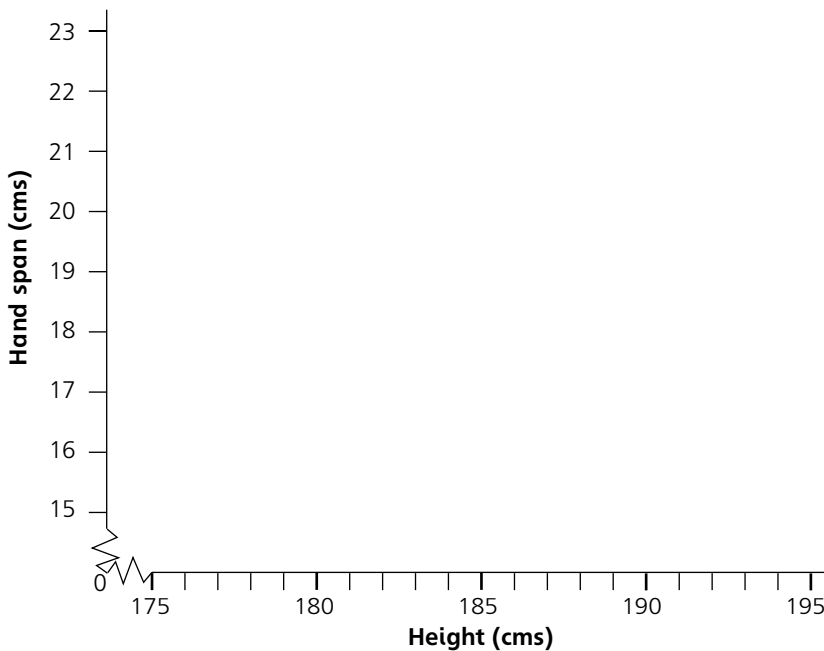

- c Describe the relationship shown by the scatter graph. ....
- d Use the line of best fit to answer the following questions. Draw dotted lines on your graph to show how you worked out the answer.
  - i Ken is 185 cm tall. Estimate his hand span. di.....
  - ii Len has a hand span of 21 cm. Estimate his height. ii.....
  - iii Mark is 177 cm tall. Estimate his hand span. iii.....
  - iv Ned has a hand span of 16 cm. Estimate his height. iv.....
  - v Owen is 192 cm tall. Estimate his hand span. v.....



# 100 Estimate of probability by experiment

- 1 John kept a record of the number of goals he scored in 100 matches. This table shows the results.

Number of goals	0	1	2	3
Frequency	40	32	24	4

Use the results to estimate the probability of scoring (write your answer as a decimal):

- a 0 goals 1a.....
- b 1 goal b.....
- c 2 goals c.....
- d 3 goals d .....

in the next match.

- 2 A dress manufacturer decided to make 100 000 dresses. Two researchers were sent to find the sizes of women. This table shows their results.

Miss Barber asked 10 people.

Mrs Jarvis asked 1000 people.

Size	8	10	12	14	16
Miss Barber	3	1	1	3	2
Mrs Jarvis	54	183	320	275	168

- a Explain why you should use Mrs Jarvis' results instead of Miss Barber's results.

.....  
 .....  
 .....

- b Use Mrs Jarvis' results to decide how many of each size should be made.

- Size 8 .....
- Size 10 .....
- Size 12 .....
- Size 14 .....
- Size 16 .....

# 101 Tree diagrams - 1

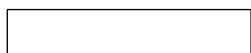

1 Four coins are tossed. Complete this tree diagram:

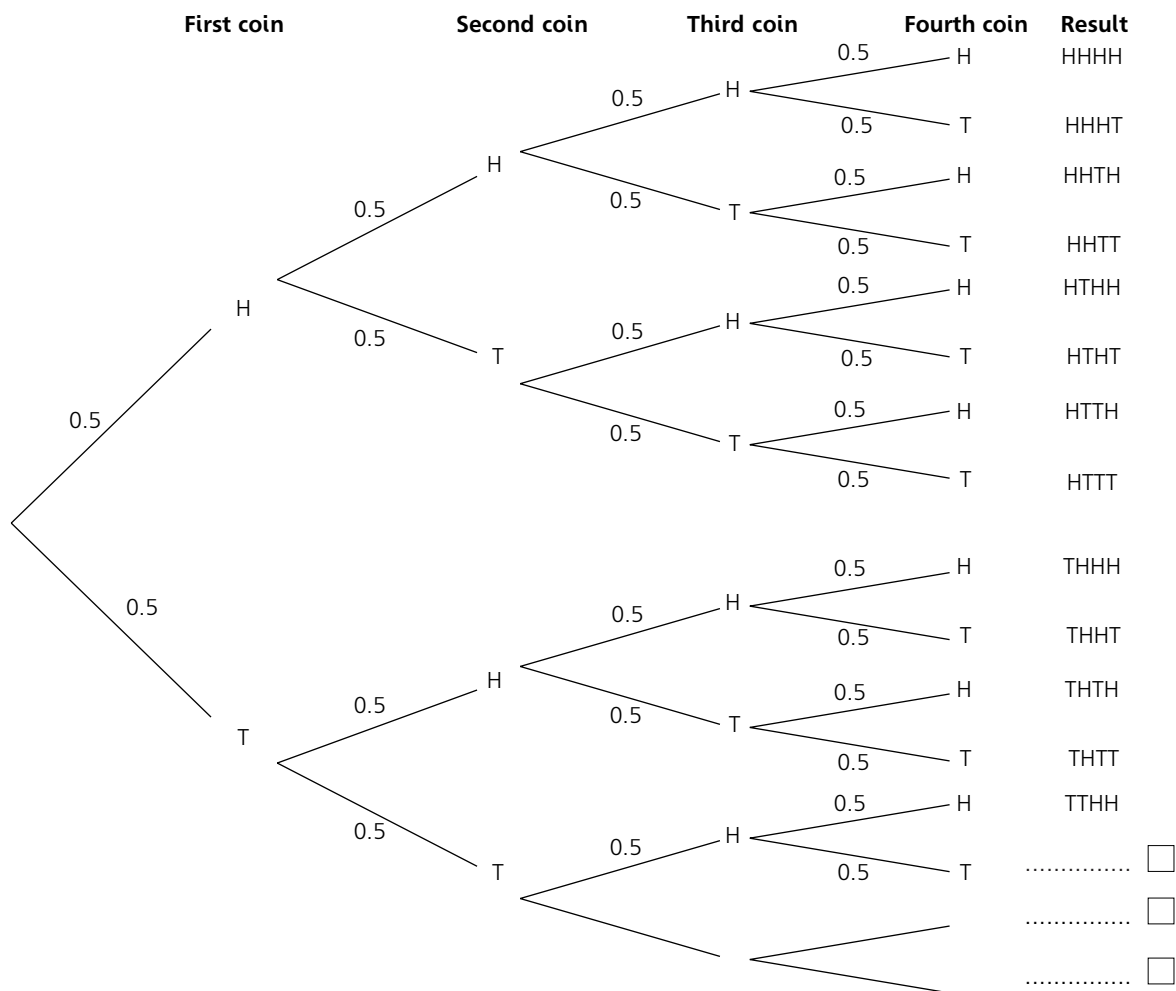

Use your tree diagram to find the probability of:

- a four heads 1a.....
- b at least three heads b.....
- c exactly two heads c.....
- d exactly one head d.....
- e no heads e.....



# 102 Tree diagrams – 2

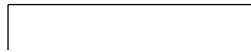

- 1 Mandy takes two examinations.  
 Her chance of passing English is 0.6, her chance of passing maths is 0.7.  
 Complete this tree diagram.

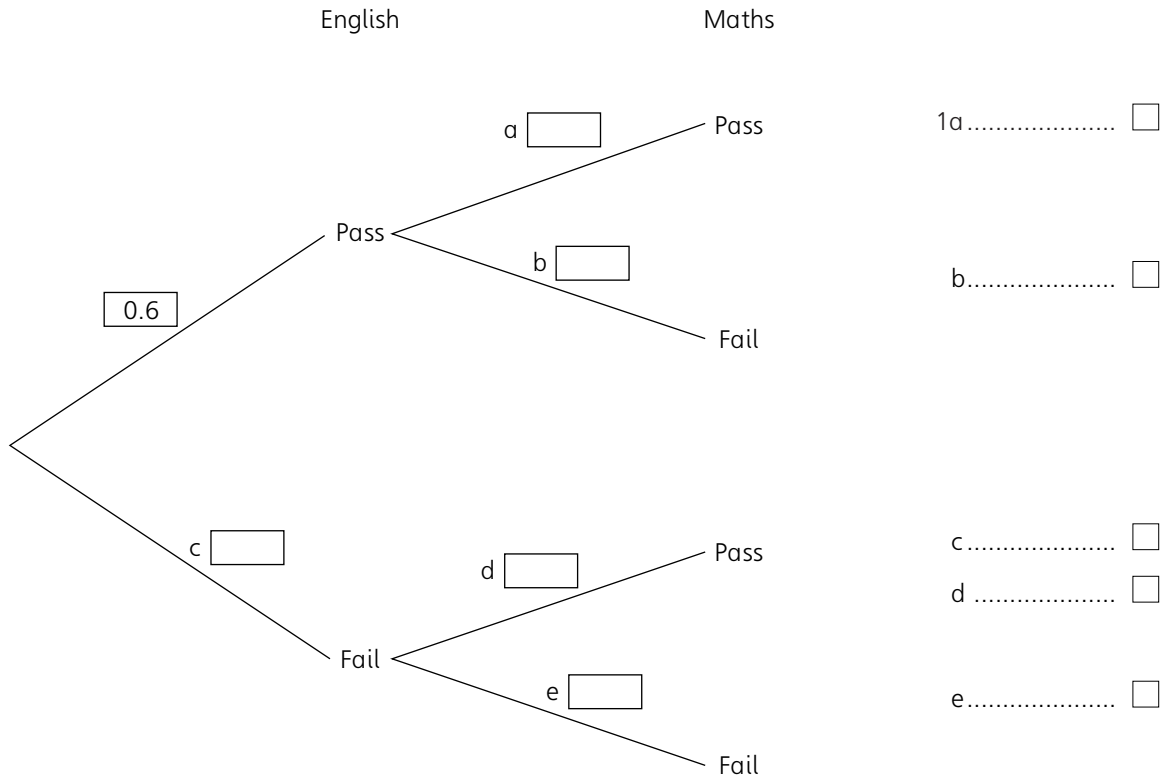

Use the tree diagram to find the probability of:

- f passing both subjects f.....
- g passing exactly one subject g.....
- h failing maths h.....
- i failing both subjects i.....
- j passing at least one subject j.....



# 103 Conditional and independent probability

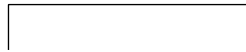

- 1 The probability of rain on any day is 0.4.  
On a rainy day the chance of Mrs Jones being late for work is 0.6.  
On a dry day her chance of being late for work is 0.1.  
Mrs Jones starts a new job.
- a What is her chance of being late on the first day? 1a.....
- b What is her chance of being late on the second day? b.....
- c If she is late on all of the first three days, she will be sacked.  
What are her chances of being sacked? c.....
- d There are 250 working days in a year. How many days do you  
expect Mrs Jones to be late during the year? d .....
- 2 Mr White buys three tickets in a raffle. 100 tickets are sold and  
there is one prize. Mrs White buys four tickets in a different raffle.  
500 tickets are sold and there is one prize. (Give answers in decimals.)
- a What is the probability that Mr White wins? 2a.....
- b What is the probability that Mr White and Mrs White both win? b.....
- c What is the probability that one wins and one loses? c.....
- d What is the probability that they both lose? d .....





# 104 Probability: And/or

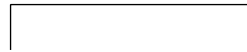

Give all answers as fractions in their lowest terms.

1 A die is thrown to decide which bag to choose from.

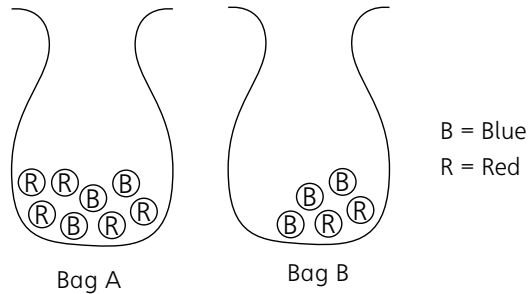

If a 5 or 6 is thrown, bag A is chosen. If a 1, 2, 3 or 4 is thrown, bag B is chosen.

A counter is selected. What is the probability that it is:

- a a red disc from bag A 1a.....
- b a blue disc from bag B b.....
- c a blue disc c.....
- d a red disc? d .....

2 Look at bag B above. Discs are chosen at random without replacement.

Two discs are chosen. What is the probability that:

- a both discs are red 2a.....
- b both discs are blue b.....
- c one of each colour is selected? c.....



# 105 Probability: At least – 1

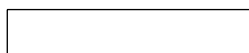

- 1 Three dice are thrown.  
What is the probability of not throwing a six? 1.....
  
- 2 Four coins are tossed.  
What is the probability of at least one head? 2.....
  
- 3 A die is thrown.  
What is the probability of shaking:
  - a a 3? 3a.....
  - b a 4 or a 6? b.....
  - c a 3 or more? c.....
  - d less than 3? d.....
  - e a 7? e.....



# 106 Probability: At least – 2

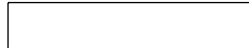

Give all answers as decimals.

1 Five coins are tossed.

a What is the probability of five heads?

1a .....

b What is the probability of at least one head?

b .....

2 Two dice are thrown and the totals added.

What is the probability of a total of 3 or more?

2 .....

3 Four dice are thrown and the totals added.

What is the probability of a total of 5 or more?

3 .....

4 A die is thrown. What is the probability of throwing:

a a 4?

4a .....

b 4 or more?

b .....

c less than 3?

c .....



# 107 Probability: Examination-type questions

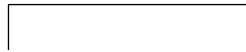

1 Complete this tree diagram to show all of the possible outcomes when three coins are tossed:

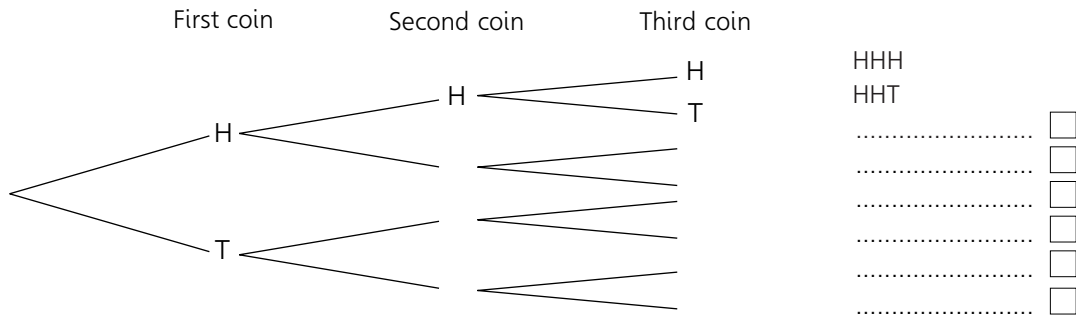

2 A four-sided spinner is spun twice. The numbers are added together and recorded in a table. Complete the table.

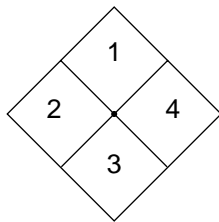

		1st spin				
		+	1	2	3	4
2nd spin	1					
	2					<input type="checkbox"/>
	3					
	4					

Use your table to answer these questions:

- a What is the probability of a total of 7? 2a.....
- b What is the probability of a total of 6 or more? b.....
- c What is the most likely total? c.....

3 When a rocket is launched, the event is either a success or a failure. The probability of a success is 0.98. What is the probability of a failure? 3.....

